

# 320E L

Hydraulic Excavator



## Engine

Engine Model	Cat® C6.6 ACERT™	
Net Power – SAE J1349	114 kW	153 hp
Gross Power – SAE J1995	122 kW	164 hp

## Drive

Maximum Travel Speed	5.6 km/h	3.5 mph
Maximum Drawbar Pull	205 kN	46,086 lbf

## Weight

Minimum Weight	21 500 kg	47,400 lb
Maximum Weight	24 730 kg	54,450 lb

# 320E L Hydraulic Excavator Specifications

## Engine

Engine Model	Cat® C6.6 ACERT™	
Net Power – SAE J1349	114 kW	153 hp
Gross Power – SAE J1995	122 kW	164 hp
Bore	105 mm	4.1 in
Stroke	127 mm	5.0 in
Displacement	6.6 L	403 in <sup>3</sup>

## Weights

Minimum Operating Weight*	21 500 kg	47,400 lb
Maximum Operating Weight**	24 730 kg	54,450 lb

\*HD 5.7 m (18'8") boom, HD 3.9 m (12'10") stick, 3.55 mt (3.9 ton) counterweight, 1.19 m<sup>3</sup> (1.56 yd<sup>3</sup>), 600 mm (24") shoes.

\*\*HD 5.7 m (18'8") boom, ES 2.9 m (9'6") stick, 5.4 mt (5.9 ton) counterweight (heavy counterweight configuration), 1.19 m<sup>3</sup> (1.56 yd<sup>3</sup>), 790 mm (31") shoes.

## Hydraulic System

Main System – Maximum Flow (Total)	428 L/min	113.1 gal/min
Maximum Pressure – Equipment		
– Heavy Lift	38 000 kPa	5,511 psi
– Normal	35 000 kPa	5,076 psi
Maximum Pressure – Travel	35 000 kPa	5,076 psi
Maximum Pressure – Swing	25 000 kPa	3,626 psi
Pilot System – Maximum Flow	24.3 L/min	6.4 gal/min
Pilot System – Maximum Pressure	3920 kPa	569 psi
Boom Cylinder – Bore	120 mm	4.7 in
Boom Cylinder – Stroke	1260 mm	49.6 in
Stick Cylinder – Bore	140 mm	5.5 in
Stick Cylinder – Stroke	1504 mm	59.2 in
B1 Bucket Cylinder – Bore	120 mm	4.7 in
B1 Bucket Cylinder – Stroke	1104 mm	43.5 in

## Drive

Maximum Travel Speed	5.6 km/h	3.5 mph
Maximum Drawbar Pull	205 kN	46,086 lbf

## Swing Mechanism

Swing Speed	11.2 rpm
Swing Torque	61.8 kN·m 45,581 lb-ft

## Service Refill Capacities

Fuel Tank Capacity	410 L	108.3 gal
Cooling System	30 L	7.9 gal
Engine Oil (with filter)	23 L	6.1 gal
Swing Drive	8 L	2.1 gal
Final Drive (each)	8 L	2.1 gal
Hydraulic System (including tank)	260 L	68.7 gal
Hydraulic Tank	143 L	37.8 gal

## Track

Number of Shoes (each side)	
– Long Undercarriage	49 pieces
Number of Track Rollers (each side)	
– Long Undercarriage	8 pieces
Number of Carrier Rollers (each side)	
– Long Undercarriage	2 pieces

## Sound Performance

Operator Noise (Closed) – ISO 6396	71 dB(A)
Spectator Noise – ISO 6395	103 dB(A)

- When properly installed and maintained, the cab offered by Caterpillar, when tested with doors and windows closed according to ANSI/SAE J1166 OCT98, meets OSHA and MSHA requirements for operator sound exposure limits in effect at time of manufacture.
- Hearing protection may be needed when operating with an open operator station and cab (when not properly maintained or doors/windows open) for extended periods or in noisy environment.

## Standards

Brakes	ISO 10265 2008
Cab/FOGS	ISO 10262 1998
Cab/ROPS	ISO 12117-2 2008

# 320E L Hydraulic Excavator Specifications

## Dimensions

All dimensions are approximate.

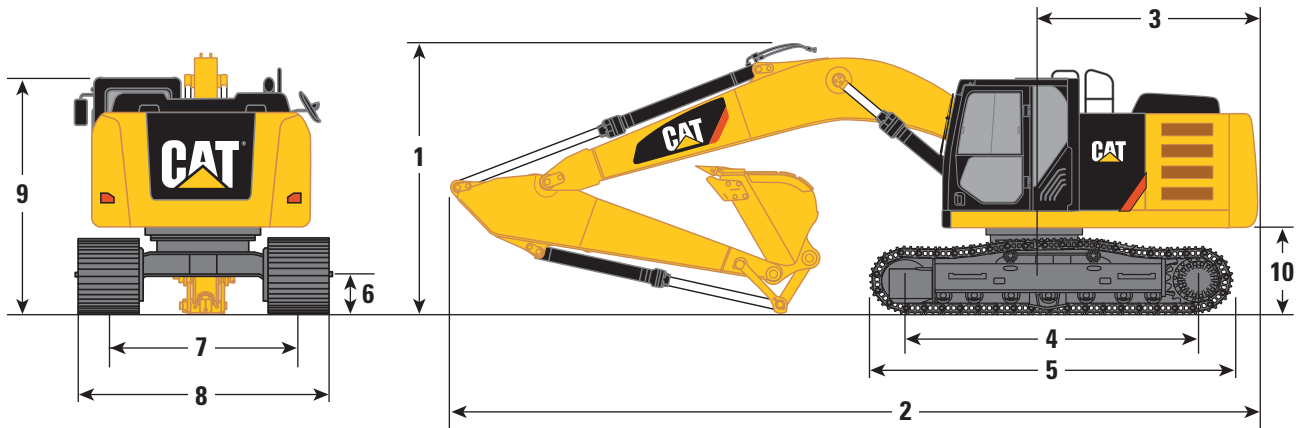

	<b>Super Long Reach Boom 8.85 m (29'0")</b>
<b>Stick</b>	<b>Super Long Reach 6.28 m (20'6")***</b>
	<b>mm (ft)</b>
<b>1</b> Shipping Height†	3180 (10'4")
Shipping Height with Guard Rail	3240 (10'8")
Shipping Height with Top Guard	3150 (10'3")
<b>2</b> Shipping Length	12 750 (41'10")
<b>3</b> Tail Swing Radius	2830 (9'3")
<b>4</b> Length to Center of Rollers	3650 (12'0")
<b>5</b> Track Length	4460 (14'6")
<b>6</b> Ground Clearance	450 (1'6")
<b>7</b> Track Gauge	2380 (7'10")
<b>8</b> Transport Width	
600 mm (24") Shoes	2980 (9'9")
790 mm (31") Shoes	3170 (10'5")
<b>9</b> Cab Height	2960 (9'9")
Cab Height with Top Guard	3150 (10'3")
<b>10</b> Counterweight Clearance††	1020 (3'4")

\*Cat 900 mm (36"), 0.81 m<sup>3</sup> (1.06 yd<sup>3</sup>) GD bucket with 1557 mm (5'1") tip radius.

\*\*Cat 1200 mm (48"), 1.19 m<sup>3</sup> (1.56 yd<sup>3</sup>) HD bucket with 1571 mm (5'2") tip radius.

\*\*\*Cat 1100 mm (44"), 0.61 m<sup>3</sup> (0.8 yd<sup>3</sup>) ditch cleaning bucket with 1092 mm (3'7") tip radius.

†Including shoe lug height without guard rail.

††Without shoe lug height.

## Working Ranges

All dimensions are approximate.

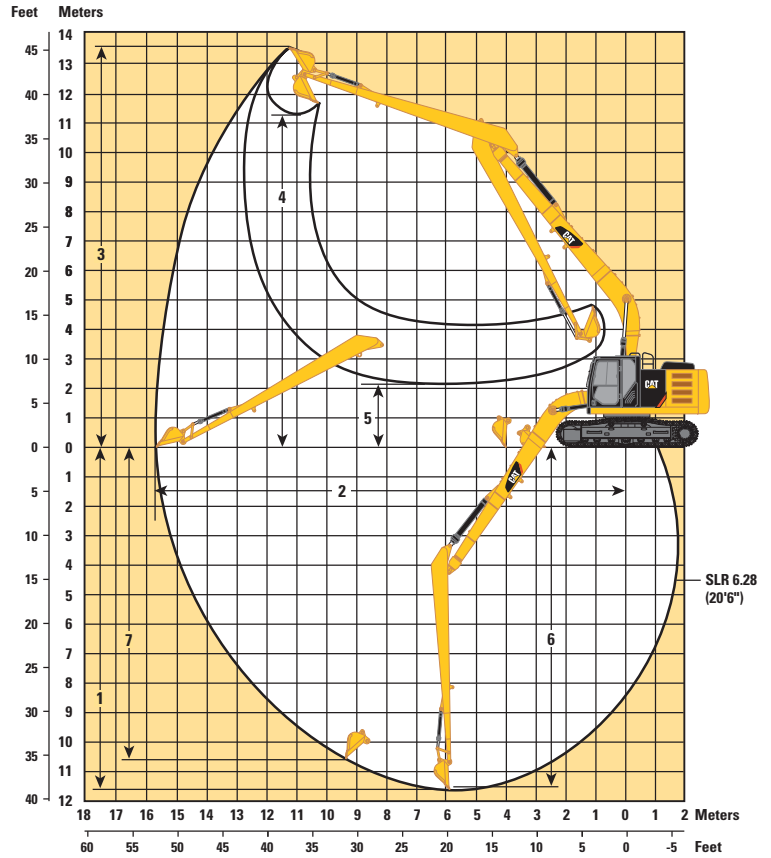
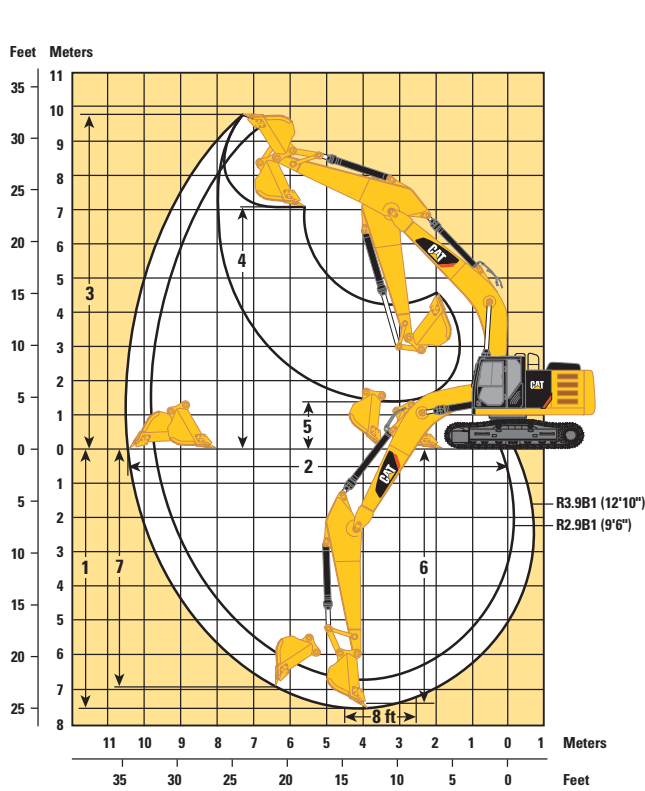

### Super Long Reach Boom 8.85 m (29'0")

#### Stick

#### Super Long Reach 6.28 m (20'6")\*\*\*

mm (ft)

Stick	mm (ft)
1 Maximum Digging Depth	11 690 (38'4")
2 Maximum Reach at Ground Level	15 720 (51'6")
3 Maximum Cutting Height	13 590 (44'6")
4 Maximum Loading Height	11 290 (37'0")
5 Minimum Loading Height	2090 (6'9")
6 Maximum Depth Cut for 2440 mm (8'0") Level Bottom	11 590 (38'0")
7 Maximum Vertical Wall Digging Depth	10 670 (35'0")

\*Cat 900 mm (36"), 0.81 m<sup>3</sup> (1.06 yd<sup>3</sup>) GD bucket with 1557 mm (5'1") tip radius.

\*\*Cat 1200 mm (48"), 1.19 m<sup>3</sup> (1.56 yd<sup>3</sup>) HD bucket with 1571 mm (5'2") tip radius.

\*\*\*Cat 1100 mm (44"), 0.61 m<sup>3</sup> (0.8 yd<sup>3</sup>) ditch cleaning bucket with 1092 mm (3'7") tip radius.

# 320E L Hydraulic Excavator Specifications

## Major Component Weights

	kg	lb
Base Machine (with boom cylinder, without counterweight, front linkage and track)	11 300	24,920
Long Undercarriage	7850	17,300
Counterweight		
3.55 mt (3.9 ton) Standard	3550	7,830
4.6 mt (5.1 ton) Super Long Reach	4600	10,140
5.4 mt (5.9 ton) Heavy	5400	11,910
Boom (includes lines, pins and stick cylinder)		
Boom HD – 5.7 m (18'8")	1720	3,790
Boom ES – 5.7 m (18'8")	2010	4,430
Boom HD for CGC – 5.7 m (18'8")	1730	3,810
Boom ES for CGC – 5.7 m (18'8")	2020	4,450
Super Long Reach – 8.85 m (29'0")	2400	5,290
Stick (includes lines, pins and bucket cylinder)		
3.9B1 (12'10") HD	930	2,060
2.9B1 (9'6") HD	680	1,510
2.9B1 (9'6") ES	840	1,850
2.9B1 (9'6") HD for CGC	690	1,530
2.9B1 (9'6") ES for CGC	850	1,870
Super Long Reach	1240	2,740
Track Shoe (Long/per two tracks)		
600 mm (24") Triple Grouser	2700	5,940
790 mm (31") Triple Grouser	3360	7,410
790 mm (31") Triple Grouser HD	3800	8,370
Quick Coupler		
Center-Lock 252	420	920
Buckets		
B1 900 mm (36") GD 347-6707 SAE 0.8 m <sup>3</sup> (1.06 yd <sup>3</sup> )	650	1,420
B1 1200 mm (48") HD 347-6731 SAE 1.19 m <sup>3</sup> (1.56 yd <sup>3</sup> )	930	2,050

All weights are rounded up to nearest 10 kg and lb except for quick coupler and buckets. Kg and lb were rounded up separately so some of the kg and lb do not match. Base machine includes 75 kg (165 lb) operator weight, 90% fuel weight, and undercarriage with center guard.

## Operating Weight and Ground Pressure

	320E L			
	790 mm (31") Triple Grouser Shoes		600 mm (24") Triple Grouser Shoes	
	kg (lb)	kPa (psi)	kg (lb)	kPa (psi)
Boom HD – 5.7 m (18'8")				
3.9B1 (12'10") HD	22 200 (48,940)	35.0 (5.08)	21 500 (47,400)	44.7 (6.48)
2.9B1 (9'6") HD	22 200 (48,940)	35.1 (5.10)	21 600 (47,620)	44.9 (6.51)
2.9B1 (9'6") ES	22 400 (49,380)	35.4 (5.13)	21 700 (47,840)	45.2 (6.56)
2.9B1 (9'6") ES with Heavy Counterweight	24 700 (54,450)	38.9 (5.64)		
Boom ES – 5.7 m (18'8")				
3.9B1 (12'10") HD	22 500 (49,600)	35.5 (5.15)	21 800 (48,060)	45.4 (6.58)
2.9B1 (9'6") HD	22 600 (49,820)	35.7 (5.18)	21 900 (48,280)	45.6 (6.61)
2.9B1 (9'6") ES	22 700 (50,040)	35.9 (5.21)	22 100 (48,720)	45.9 (6.66)
Super Long Reach Boom – 8.85 m (29'0")				
6.28 m (20'6") SLR	23 500 (51,810)	37.1 (5.38)	22 800 (50,270)	47.4 (6.87)

## Bucket and Stick Forces

Stick	Heavy Duty and Extreme Service Booms 5.7 m (18'8")		Super Long Reach Boom 8.85 m (29'0")
	3.9B1 (12'10")	2.9B1 (9'6")	Super Long Reach 6.28 m (20'6")
B1 – Family Bucket	kN (lbf)	kN (lbf)	kN (lbf)
General Duty			
Bucket Digging Force (SAE)	125.9 (28,300)	125.9 (28,300)	51.2 (11,500)
Stick Digging Force (SAE)	87.8 (19,700)	103.9 (23,400)	35.8 (8,000)
Heavy Duty			
Bucket Digging Force (SAE)	124.4 (28,000)	133.5 (30,000)	
Stick Digging Force (SAE)	87.6 (19,700)	103.2 (23,200)	
Severe Duty			
Bucket Digging Force (SAE)	124.4 (28,000)	133.5 (30,000)	
Stick Digging Force (SAE)	87.6 (19,700)	103.2 (23,200)	



# 320E L Hydraulic Excavator Specifications

## HD Boom Lift Capacities



Load Point Height



Load at Maximum Reach



Load Radius Over Front



Load Radius Over Side

Boom – 5.7 m (18'8")

















Counterweight – 3.55 mt (3.9 t)

Bucket – None

Stick – 3.9B1 (12'10")

Shoes – 790 mm (31") triple grouser

Heavy Lift Mode On

	1.5 m/5.0 ft		3.0 m/10.0 ft		4.5 m/15.0 ft		6.0 m/20.0 ft		7.5 m/25.0 ft		9.0 m/30.0 ft				m ft		
																	
7.5 m 25.0 ft	kg lb														*3000 *6,600	*3000 *6,600	7.32 23.69
6.0 m 20.0 ft	kg lb									*4550 *9,600	3800 8,150				*2800 *6,150	*2800 *6,150	8.29 27.05
4.5 m 15.0 ft	kg lb									*4800 *10,550	3750 8,000				*2750 *6,050	*2750 *6,050	8.91 29.17
3.0 m 10.0 ft	kg lb					*7150 *15,450	*7150 *15,450	*5950 *12,850	5050 10,900	*5300 *11,550	3600 7,750	*3850 *7,150	2700 5,750		*2800 *6,150	2550 5,650	9.25 30.31
1.5 m 5.0 ft	kg lb			*9800 *23,300	*9800 *23,300	*9300 *20,050	7250 15,600	*7000 *15,150	4800 10,300	5450 11,750	3450 7,400	4150 *8,500	2600 5,600		*2950 *6,450	2450 5,400	9.33 30.60
Ground Line	kg lb			*8050 *18,450	*8050 *18,450	*10 850 *23,400	6800 14,650	7400 15,950	4550 9,750	5300 11,400	3300 7,150	4100 *7,250	2550 5,500		*3200 *7,050	2500 5,450	9.16 30.05
-1.5 m -5.0 ft	kg lb	*6050 *13,500	*6050 *13,500	*10 400 *23,550	*10 400 *23,550	*11 500 24,700	6600 14,200	7250 15,600	4400 9,450	5250 11,250	3250 6,950				*3650 *8,000	2650 5,800	8.73 28.61
-3.0 m -10.0 ft	kg lb	*9400 *21,050	*9400 *21,050	*14 400 *32,750	12 700 27,200	*11 350 *24,550	6550 14,150	7200 15,500	4350 9,400	5250 11,250	3250 6,950				*4450 *9,850	3000 6,600	8.00 26.15
-4.5 m -15.0 ft	kg lb	*13 650 *30,750	*13 650 *30,750	*14 750 *31,700	12 950 27,750	*10 250 *22,000	6700 14,400	7300 15,750	4450 9,600						6050 *13,450	3750 8,350	6.86 22.30
-6.0 m	kg					*7250	7000								*6400	6200	4.91

Boom – 5.7 m (18'8")















Counterweight – 3.55 mt (3.9 t)

Bucket – None

Stick – 2.9B1 (9'6")

Shoes – 790 mm (31") triple grouser

Heavy Lift Mode On

	1.5 m/5.0 ft		3.0 m/10.0 ft		4.5 m/15.0 ft		6.0 m/20.0 ft		7.5 m/25.0 ft				m ft	
														
7.5 m 25.0 ft	kg lb							*4950 *4950				*4300 *9,500	*4300 *9,500	6.15 19.78
6.0 m 20.0 ft	kg lb							*5450 *12,000	5400 11,600			*3950 *8,750	3950 *8,750	7.28 23.71
4.5 m 15.0 ft	kg lb							*6000 *13,050	5250 11,300	*5650 12,300	3750 8,000	*3900 *8,550	3350 7,450	7.98 26.10
3.0 m 10.0 ft	kg lb					*8750 *18,850	7650 16,500	*6900 *14,950	5050 10,850	5650 12,100	3650 7,800	*4000 *8,750	3050 6,750	8.35 27.38
1.5 m 5.0 ft	kg lb					*10 600 *22,900	7150 15,450	7700 16,550	4800 10,350	5500 11,850	3500 7,550	*4200 *9,250	2950 6,500	8.44 27.70
Ground Line	kg lb			*6600 *15,150	*6600 *15,150	*11 650 *25,200	6900 14,850	7500 16,100	4650 10,000	5400 11,650	3450 7,400	*4650 *10,250	3000 6,600	8.26 27.09
-1.5 m -5.0 ft	kg lb	*7050 *15,750	*7050 *15,750	*11 400 *25,850	*11 400 *25,850	11 750 25,150	6800 14,650	7400 15,950	4550 9,800	5400 11,600	3400 7,350	5150 11,300	3250 7,150	7.78 25.48
-3.0 m -10.0 ft	kg lb	*12 100 *27,100	*12 100 *27,100	*15 600 *33,750	13 250 28,350	*11 000 *23,800	6850 14,750	7450 16,000	4600 9,900			6050 13,450	3800 8,450	6.94 22.67
-4.5 m -15.0 ft	kg lb			*12 450 *26,650	*12 450 *26,650	*8950 *19,050	7050 15,200					*6800 *14,900	5250 11,750	5.60 18.08

\*Indicates that the load is limited by hydraulic lifting capacity rather than tipping load. The above loads are in compliance with hydraulic excavator lift capacity standard ISO 10567:2007. They do not exceed 87% of hydraulic lifting capacity or 75% of tipping load. Weight of all lifting accessories must be deducted from the above lifting capacities. Lifting capacities are based on the machine standing on a firm, uniform supporting surface. The use of a work tool attachment point to handle/lift objects, could affect the machine lift performance.

Always refer to the appropriate Operation and Maintenance Manual for specific product information.

## ES Boom Lift Capacities



Load Point Height



Load at Maximum Reach



Load Radius Over Front



Load Radius Over Side

**Boom** – 5.7 m (18'8")

**Counterweight** – 3.55 mt (3.9 t)

**Bucket** – None

**Stick** – 2.9B1 (9'6")

**Shoes** – 790 mm (31") triple grouser

**Heavy Lift Mode On**

 7.5 m 25.0 ft kg lb	1.5 m/5.0 ft		3.0 m/10.0 ft		4.5 m/15.0 ft		6.0 m/20.0 ft		7.5 m/25.0 ft		 m ft								
	 kg lb	 kg lb	 kg lb	 kg lb	 kg lb	 kg lb	 kg lb	 kg lb	 kg lb	 kg lb	 kg lb	 kg lb	m ft						
							*4900	*4900			*4200	*4200	6.15						
							*5300	*5300			*3900	3800	7.28						
							*11,650	11,450			*8,600	8,500	23.71						
							*5850	5150	*5450	3600	*3850	3250	7.98						
							*12,700	11,100	*12,000	7,700	*8,400	7,150	26.10						
							*8550	7500	*6700	4900	5500	3500	*3900	2950	8.35				
							*18,350	16,150	*14,500	10,500	11,850	7,500	*8,600	6,450	27.38				
							*10 300	6950	7550	4650	5350	3350	*4150	2800	8.44				
							*22,250	14,950	16,200	9,950	11,550	7,200	*9,150	6,200	27.70				
							*6550	*6550	*11 300	6600	7300	4450	5250	3250	4600	2850	8.26		
							*15,000	*15,000	*24,450	14,250	15,700	9,550	11,300	7,000	10,100	6,250	27.09		
							*7000	*7000	*11 350	*11 350	*11 400	6550	7200	4350	5250	3250	5000	3100	7.78
							*15,600	*15,600	*25,700	*25,700	24,550	14,050	15,500	9,350	11,250	6,950	10,950	6,800	25.48
							*12 000	*12 000	*15 150	12 800	*10 650	6600	7250	4400			5900	3650	6.94
							*26,950	*26,950	*32,750	27,400	*23,050	14,150	15,600	9,450			13,050	8,050	22.67
							*12 050	*12 050	*8650	6800							*6550	5050	5.60
							*25,750	*25,750	*18,400	14,700							*14,350	11,350	18.08

\*Indicates that the load is limited by hydraulic lifting capacity rather than tipping load. The above loads are in compliance with hydraulic excavator lift capacity standard ISO 10567:2007. They do not exceed 87% of hydraulic lifting capacity or 75% of tipping load. Weight of all lifting accessories must be deducted from the above lifting capacities. Lifting capacities are based on the machine standing on a firm, uniform supporting surface. The use of a work tool attachment point to handle/lift objects, could affect the machine lift performance.

Always refer to the appropriate Operation and Maintenance Manual for specific product information.



# 320E L Hydraulic Excavator Specifications

## HD Boom Lift Capacities



Load Point Height



Load at Maximum Reach



Load Radius Over Front



Load Radius Over Side

**Boom** – 5.7 m (18'8")















**Counterweight** – 5.4 mt (5.9 t)

**Bucket** – None

**Stick** – 2.9B1 (9'6") ES

**Shoes** – 790 mm (31") triple grouser

**Heavy Lift Mode On**

		1.5 m/5.0 ft		3.0 m/10.0 ft		4.5 m/15.0 ft		6.0 m/20.0 ft		7.5 m/25.0 ft				m ft
														
7.5 m 25.0 ft	kg lb							*4900	*4900			*4200	*4200	6.15 19.78
6.0 m 20.0 ft	kg lb							*5900	*5900			*3900	*3900	7.28 23.71
4.5 m 15.0 ft	kg lb							*6500	6350	*6100	4550	*3850	*3850	7.98 26.10
3.0 m 10.0 ft	kg lb					*9500	9250	*7450	6100	*6550	4400	*3900	3750	8.35 27.38
1.5 m 5.0 ft	kg lb					*11 500	8750	*8500	5850	6550	4300	*4150	3650	8.44 27.70
Ground Line	kg lb			*6550	*6550	*12 650	8450	8950	5700	6450	4200	*4600	3700	8.26 27.09
-1.5 m -5.0 ft	kg lb	*7000	*7000	*11 350	*11 350	*12 750	8400	8850	5600	6450	4200	*5400	4000	7.78 25.48
-3.0 m -10.0 ft	kg lb	*12 000	*12 000	*16 950	16 250	*11 950	8450	*8900	5650			*7000	4700	6.94 22.67
-4.5 m -15.0 ft	kg lb			*13 550	*13 550	*9750	8650					*7350	6400	5.60 18.08

\*Indicates that the load is limited by hydraulic lifting capacity rather than tipping load. The above loads are in compliance with hydraulic excavator lift capacity standard ISO 10567:2007. They do not exceed 87% of hydraulic lifting capacity or 75% of tipping load. Weight of all lifting accessories must be deducted from the above lifting capacities. Lifting capacities are based on the machine standing on a firm, uniform supporting surface. The use of a work tool attachment point to handle/lift objects, could affect the machine lift performance.

Always refer to the appropriate Operation and Maintenance Manual for specific product information.

## Super Long Reach Boom Lift Capacities



Load Point Height



Load at Maximum Reach



Load Radius Over Front



Load Radius Over Side















**Boom** – 8.85 m (29'0")

**Counterweight** – 4.6 mt (5.1 t)

**Bucket** – None

**Stick** – 6.28 m (20'6") Super Long Reach

**Shoes** – 790 mm (31") triple grouser

	1.5 m/5.0 ft		3.0 m/10.0 ft		4.5 m/15.0 ft		6.0 m/20.0 ft		7.5 m/25.0 ft				m ft	
														
12.0 m 40.0 ft	kg lb											*1250 *2,800	*1250 *2,800	10.35 33.31
10.5 m 35.0 ft	kg lb											*1200 *2,600	*1200 *2,600	11.66 37.83
9.0 m 30.0 ft	kg lb											*1150 *2,450	*1150 *2,450	12.66 41.25
7.5 m 25.0 ft	kg lb											*1100 *2,400	*1100 *2,400	13.41 43.83
6.0 m 20.0 ft	kg lb											*1100 *2,400	*1100 *2,400	13.96 45.71
4.5 m 15.0 ft	kg lb											*1100 *2,400	*1100 *2,400	14.34 46.99
3.0 m 10.0 ft	kg lb			*4700 *11,850	*4700 *11,850	*5950 *12,700	*5950 *12,700	*4350 *9,400	*4350 *9,400	*3550 *7,650	*3550 *7,650	*1150 *2,500	*1150 *2,500	14.54 47.71
1.5 m 5.0 ft	kg lb					*6750 *15,750	6500 14,000	*5150 *11,050	4500 9,700	*4000 *8,700	3300 7,150	*1200 *2,600	1100 2,400	14.60 47.89
Ground Line	kg lb			*2000 *4,550	*2000 *4,550	*4650 *10,700	*4650 *10,700	*5750 *12,400	4000 8,650	*4450 *9,550	3000 6,500	*1250 *2,750	1100 2,350	14.49 47.54
-1.5 m -5.0 ft	kg lb	*2050 *4,550	*2050 *4,550	*2700 *6,050	*2700 *6,050	*4650 *10,500	*4650 *10,500	*6100 *13,250	3750 8,000	*4700 *10,200	2800 6,000	*1350 *2,950	1100 2,400	14.22 46.65
-3.0 m -10.0 ft	kg lb	*2850 *6,350	*2850 *6,350	*3500 *7,850	*3500 *7,850	*5200 *11,750	*5200 *11,500	*6250 *13,550	3600 7,700	4700 10,150	2650 5,700	*1500 *3,300	1150 2,500	13.79 45.19
-4.5 m -15.0 ft	kg lb	*3650 *8,150	*3650 *8,150	*4400 *9,900	*4400 *9,900	*6050 *13,700	5400 11,550	*6250 *13,450	3550 7,600	4650 10,000	2600 5,600	*1700 *3,750	1200 2,700	13.17 43.10
-6.0 m -20.0 ft	kg lb	*4550 *10,100	*4550 *10,100	*5400 *12,150	*5400 *12,150	*7200 *16,350	5500 11,850	*6000 *12,900	3600 7,700	4650 10,050	2600 5,650	*2000 *4,450	1350 3,000	12.34 40.27
-7.5 m -25.0 ft	kg lb	*5500 *12,250	*5500 *12,250	*6550 *14,800	*6550 *14,800	*7100 *15,250	5700 12,300	*5500 *11,850	3700 7,950	*4450 *9,500	2700 5,800	*2500 *5,650	1600 3,550	11.24 36.55
-9.0 m -30.0 ft	kg lb			*7950 *16,950	*7950 *16,950	*5950 *12,700	*5950 *12,700	*4700 *10,050	3900 8,400	*3800 *8,050	2850 6,150	*2600 *5,700	2050 4,600	9.79 31.60

\*Indicates that the load is limited by hydraulic lifting capacity rather than tipping load. The above loads are in compliance with hydraulic excavator lift capacity standard ISO 10567:2007. They do not exceed 87% of hydraulic lifting capacity or 75% of tipping load. Weight of all lifting accessories must be deducted from the above lifting capacities. Lifting capacities are based on the machine standing on a firm, uniform supporting surface. The use of a work tool attachment point to handle/lift objects, could affect the machine lift performance.

Always refer to the appropriate Operation and Maintenance Manual for specific product information.

# 320E L Hydraulic Excavator Specifications

## Super Long Reach Boom Lift Capacities



Load Point Height



Load at Maximum Reach



Load Radius Over Front



Load Radius Over Side











**Boom** – 8.85 m (29'0")

**Counterweight** – 4.6 mt (5.1 t)

**Bucket** – None

**Stick** – 6.28 m (20'6") Super Long Reach

**Shoes** – 790 mm (31") triple grouser

	9.0 m/30.0 ft		10.5 m/35.0 ft		12.0 m/40.0 ft		13.5 m/45.0 ft				m ft	
												
12.0 m 40.0 ft	kg lb									*1250 *2,800	*1250 *2,800	10.35 33.31
10.5 m 35.0 ft	kg lb			*2150 *4,700	*2150 *4,700					*1200 *2,600	*1200 *2,600	11.66 37.83
9.0 m 30.0 ft	kg lb			*2150 *4,700	*2150 *4,700	*2000 *3,650	1950 *3,650			*1150 *2,450	*1150 *2,450	12.66 41.25
7.5 m 25.0 ft	kg lb			*2200 *4,850	*2200 *4,850	*2150 *4,750	1950 4,100			*1100 *2,400	*1100 *2,400	13.41 43.83
6.0 m 20.0 ft	kg lb			*2350 *5,100	*2350 *5,100	*2250 *4,900	1900 4,000	*1850 *3,250	1450 3,050	*1100 *2,400	*1100 *2,400	13.96 45.71
4.5 m 15.0 ft	kg lb	*2750 *5,950	*2750 *5,950	*2500 *5,450	2300 4,950	*2350 *5,100	1800 3,850	*2250 *4,600	1400 3,000	*1100 *2,400	*1100 *2,400	14.34 46.99
3.0 m 10.0 ft	kg lb	*3050 *6,600	2800 6,000	*2700 *5,900	2150 4,650	*2500 *5,400	1700 3,650	2300 4,900	1350 2,850	*1150 *2,500	*1150 *2,500	14.54 47.71
1.5 m 5.0 ft	kg lb	*3350 *7,250	2550 5,500	*2900 *6,300	2000 4,300	*2600 *5,700	1600 3,400	2200 4,750	1300 2,750	*1200 *2,600	1100 2,400	14.60 47.89
Ground Line	kg lb	*3650 *7,850	2350 5,050	*3100 *6,750	1900 4,000	2600 5,550	1500 3,250	2150 4,650	1250 2,600	*1250 *2,750	1100 2,350	14.49 47.54
-1.5 m -5.0 ft	kg lb	3800 8,100	2200 4,700	3050 6,550	1750 3,750	2500 5,400	1450 3,050	2100 4,550	1200 2,550	*1350 *2,950	1100 2,400	14.22 46.65
-3.0 m -10.0 ft	kg lb	3650 7,900	2100 4,500	2950 6,350	1700 3,600	2450 5,300	1400 2,950	2100 *3,650	1150 2,500	*1500 *3,300	1150 2,500	13.79 45.19
-4.5 m -15.0 ft	kg lb	3600 7,750	2050 4,350	2950 6,300	1650 3,550	2450 5,250	1400 2,950			*1700 *3,750	1200 2,700	13.17 43.10
-6.0 m -20.0 ft	kg lb	3600 7,800	2050 4,400	2950 6,350	1650 3,550	2500 *5,150	1400 3,050			*2000 *4,450	1350 3,000	12.34 40.27
-7.5 m -25.0 ft	kg lb	*3650 *7,750	2100 4,550	*2950 *6,250	1750 3,750					*2500 *5,650	1600 3,550	11.24 36.55
-9.0 m -30.0 ft	kg lb	*3050 *6,300	2250 4,850							*2600 *5,700	2050 4,600	9.79 31.60

\*Indicates that the load is limited by hydraulic lifting capacity rather than tipping load. The above loads are in compliance with hydraulic excavator lift capacity standard ISO 10567:2007. They do not exceed 87% of hydraulic lifting capacity or 75% of tipping load. Weight of all lifting accessories must be deducted from the above lifting capacities. Lifting capacities are based on the machine standing on a firm, uniform supporting surface. The use of a work tool attachment point to handle/lift objects, could affect the machine lift performance.

Always refer to the appropriate Operation and Maintenance Manual for specific product information.

## Work Tool Offering Guide\*

<b>Boom</b>	<b>5.7 m (18'8")</b>	
<b>Stick</b>	<b>3.9 m (12'10")</b>	<b>2.9 m (9'6")</b>
Hydraulic Hammer	H115Es H120Es H130Es**	H115Es H120Es H130Es
Multi-Processor		MP15**
Pulverizer	P215**	P215
Mobile Scrap and Demolition Shear	S325B*** S340B***	S320B** S325B*** S340B***
Compactor (Vibratory Plate)	CVP110	CVP110
Contractors' Grapple	G120B-G130B	G120B-G130B
Trash Grapple		
Thumbs		
Rakes		
Center-Lock Pin Grabber Coupler		
Dedicated Quick Coupler		

These work tools are available for the 320E.  
Consult your Cat dealer for proper match.

\*Matches are dependent on excavator configurations. Consult your Cat dealer for proper work tool match.

\*\*Pin-on only.

\*\*\*Boom-mount.

# 320E L Hydraulic Excavator Specifications

## Bucket Specifications and Compatibility

Without Quick Coupler									320E L			320E L	
	Linkage	Width		Capacity		Weight		Fill	Boom (HD)			Boom (ES)	
		mm	in	m <sup>3</sup>	yd <sup>3</sup>	kg	lb	%	3.9 HD (12'10")	2.9 HD (9'6")	2.9 ES (9'6")	3.9 HD (12'10")	2.9 ES (9'6")
General Duty (GDC)	B	600	24	0.55	0.72	618	1,363	100%	●	●	●	●	●
	B	750	30	0.75	0.98	710	1,566	100%	●	●	●	●	●
	B	900	36	0.95	1.24	786	1,733	100%	⊙	●	●	⊖	●
	B	1050	42	1.16	1.52	847	1,867	100%	○	⊙	⊙	○	⊙
	B	1200	48	1.38	1.80	925	2,038	100%	◇	⊖	⊖	◇	○
	B	1350	54	1.59	2.08	1002	2,209	100%	X	○**	○	X	○
Heavy Duty (HD)	B	600	24	0.46	0.61	649	1,430	100%	●	●	●	●	●
	B	750	30	0.64	0.84	747	1,647	100%	●	●	●	●	●
	B	900	36	0.81	1.06	825	1,818	100%	●	●	●	⊙	●
	B	1050	42	1.00	1.31	879	1,937	100%	⊖	●	●	⊖	⊙
	B	1200	48	1.19	1.56	970	2,138	100%	○	⊙	⊖	○	⊖
	B	1350	54*	1.38	1.81	1051	2,316	100%	X	⊖**	○	X	○
Severe Duty (SD)	B	600	24	0.46	0.61	693	1,527	90%	●	●	●	●	●
	B	750	30	0.64	0.84	801	1,765	90%	●	●	●	●	●
	B	900	36	0.81	1.06	887	1,955	90%	●	●	●	●	●
	B	1050	42	1.00	1.31	962	2,121	90%	⊖	●	●	⊖	●
	B	1200	48	1.19	1.56	1051	2,316	90%	○	⊙	⊙	○	⊖
Super Long Reach	SLR	813	32	0.46	0.60	341	751	100%					
	SLR	1143	45	0.61	0.80	289	637	100%					
Maximum load pin-on (payload + bucket)								kg	2480	3070	2950	2410	2870
								lb	5,466	6,766	6,502	5,312	6,325

### Maximum Material Density:

- 2100 kg/m<sup>3</sup> (3,500 lb/yd<sup>3</sup>)
- ⊙ 1800 kg/m<sup>3</sup> (3,000 lb/yd<sup>3</sup>)
- ⊖ 1500 kg/m<sup>3</sup> (2,500 lb/yd<sup>3</sup>)
- 1200 kg/m<sup>3</sup> (2,000 lb/yd<sup>3</sup>)
- ◇ 900 kg/m<sup>3</sup> (1,500 lb/yd<sup>3</sup>)
- X Not recommended

The above loads are in compliance with hydraulic excavator standard EN474, they do not exceed 87% of hydraulic lifting capacity or 75% of tipping capacity with front linkage fully extended at ground line with bucket curled.

Capacity based on ISO 7451.

Bucket weight with General Duty tips.

\*This bucket might reduce boom structure life.

\*\*For light dirt loading applications only. Consult your dealer to understand your application before using this bucket in combination with this stick.

Caterpillar recommends using appropriate work tools to maximize the value customers receive from our products. Use of work tools, including buckets, which are outside of Caterpillar's recommendations or specifications for weight, dimensions, flows, pressures, etc. may result in less-than-optimal performance, including but not limited to reductions in production, stability, reliability, and component durability. Improper use of a work tool resulting in sweeping, prying, twisting and/or catching of heavy loads will reduce the life of the boom and stick.

## Bucket Specifications and Compatibility

Without Quick Coupler									320E L**	320E L
	Linkage	Width		Capacity		Weight		Fill	Boom (HD)	SLR
		mm	in	m <sup>3</sup>	yd <sup>3</sup>	kg	lb	%	2.9 ES (9'6")	6.28 m (20'6")
General Duty (GDC)	B	600	24	0.55	0.72	618	1,363	100%	●	
	B	750	30	0.75	0.98	710	1,566	100%	●	
	B	900	36	0.95	1.24	786	1,733	100%	●	
	B	1050	42	1.16	1.52	847	1,867	100%	●	
	B	1200	48	1.38	1.80	925	2,038	100%	●	
	B	1350	54	1.59	2.08	1002	2,209	100%	⊙	
Heavy Duty (HD)	B	600	24	0.46	0.61	649	1,430	100%	●	
	B	750	30	0.64	0.84	747	1,647	100%	●	
	B	900	36	0.81	1.06	825	1,818	100%	●	
	B	1050	42	1.00	1.31	879	1,937	100%	●	
	B	1200	48	1.19	1.56	970	2,138	100%	●	
	B	1350	54*	1.38	1.81	1051	2,316	100%	●	
Severe Duty (SD)	B	600	24	0.46	0.61	693	1,527	90%	●	
	B	750	30	0.64	0.84	801	1,765	90%	●	
	B	900	36	0.81	1.06	887	1,955	90%	●	
	B	1050	42	1.00	1.31	962	2,121	90%	●	
	B	1200	48	1.19	1.56	1051	2,316	90%	●	
Super Long Reach	SLR	813	32	0.46	0.60	341	751	100%		○
	SLR	1143	45	0.61	0.80	289	637	100%		◇
Maximum load pin-on (payload + bucket)								kg	3820	915
								lb	8,419	2,017

### Maximum Material Density:

- 2100 kg/m<sup>3</sup> (3,500 lb/yd<sup>3</sup>)
- ⊙ 1800 kg/m<sup>3</sup> (3,000 lb/yd<sup>3</sup>)
- ⊖ 1500 kg/m<sup>3</sup> (2,500 lb/yd<sup>3</sup>)
- 1200 kg/m<sup>3</sup> (2,000 lb/yd<sup>3</sup>)
- ◇ 900 kg/m<sup>3</sup> (1,500 lb/yd<sup>3</sup>)

The above loads are in compliance with hydraulic excavator standard EN474, they do not exceed 87% of hydraulic lifting capacity or 75% of tipping capacity with front linkage fully extended at ground line with bucket curled.

Capacity based on ISO 7451.

Bucket weight with General Duty tips.

\*This bucket might reduce boom structure life.

\*\*Heavy counterweight configuration with 5.4 mt (5.9 ton) counterweight.

Caterpillar recommends using appropriate work tools to maximize the value customers receive from our products. Use of work tools, including buckets, which are outside of Caterpillar's recommendations or specifications for weight, dimensions, flows, pressures, etc. may result in less-than-optimal performance, including but not limited to reductions in production, stability, reliability, and component durability. Improper use of a work tool resulting in sweeping, prying, twisting and/or catching of heavy loads will reduce the life of the boom and stick.

# 320E L Hydraulic Excavator Specifications

## Bucket Specifications and Compatibility

With Center Lock Coupler									320E L			320E L	
	Linkage	Width		Capacity		Weight		Fill	Boom (HD)			Boom (ES)	
		mm	in	m <sup>3</sup>	yd <sup>3</sup>	kg	lb		%	3.9 HD (12'10")**	2.9 HD (9'6")	2.9 ES (9'6")	3.9 HD (12'10")**
General Duty (GDC)	B	600	24	0.55	0.72	618	1,363	100%	●	●	●	●	●
	B	750	30	0.75	0.98	710	1,566	100%	⊙	●	●	⊙	●
	B	900	36	0.95	1.24	786	1,733	100%	○	⊙	⊙	○	⊙
	B	1050	42	1.16	1.52	847	1,867	100%	◇	⊖	⊖	◇	○
	B	1200	48	1.38	1.80	925	2,038	100%	X	○	○	X	◇
	B	1350	54	1.59	2.08	1002	2,209	100%	X	◇	◇	X	◇
Heavy Duty (HD)	B	600	24	0.46	0.61	649	1,430	100%	●	●	●	●	●
	B	750	30	0.64	0.84	747	1,647	100%	●	●	●	⊙	●
	B	900	36	0.81	1.06	825	1,818	100%	⊖	●	●	⊖	●
	B	1050	42	1.00	1.31	879	1,937	100%	○	⊙	⊖	◇	⊖
	B	1200	48	1.19	1.56	970	2,138	100%	◇	○	○	◇	○
	B	1350	54*	1.38	1.81	1051	2,316	100%	X	○	◇	X	◇
Severe Duty (SD)	B	600	24	0.46	0.61	693	1,527	90%	●	●	●	●	●
	B	750	30	0.64	0.84	801	1,765	90%	●	●	●	●	●
	B	900	36	0.81	1.06	887	1,955	90%	⊖	●	●	⊖	●
	B	1050	42	1.00	1.31	962	2,121	90%	○	⊙	⊙	○	⊖
	B	1200	48	1.19	1.56	1051	2,316	90%	◇	⊖	○	◇	○
	B	1200	48	1.19	1.56	1000	2,204	90%	◇	⊖	⊖	◇	○
Maximum load with coupler (payload + bucket)								kg	2070	2660	2540	2000	2460
								lb	4,563	5,863	5,599	4,409	5,422

### Maximum Material Density:

- 2100 kg/m<sup>3</sup> (3,500 lb/yd<sup>3</sup>)
- ⊙ 1800 kg/m<sup>3</sup> (3,000 lb/yd<sup>3</sup>)
- ⊖ 1500 kg/m<sup>3</sup> (2,500 lb/yd<sup>3</sup>)
- 1200 kg/m<sup>3</sup> (2,000 lb/yd<sup>3</sup>)
- ◇ 900 kg/m<sup>3</sup> (1,500 lb/yd<sup>3</sup>)
- X Not recommended

The above loads are in compliance with hydraulic excavator standard EN474, they do not exceed 87% of hydraulic lifting capacity or 75% of tipping capacity with front linkage fully extended at ground line with bucket curled.

Capacity based on ISO 7451.

Bucket weight with General Duty tips.

\*This bucket might reduce boom structure life.

\*\*Auxiliary hydraulic lines available from Cat Work Tools.

Caterpillar recommends using appropriate work tools to maximize the value customers receive from our products. Use of work tools, including buckets, which are outside of Caterpillar's recommendations or specifications for weight, dimensions, flows, pressures, etc. may result in less-than-optimal performance, including but not limited to reductions in production, stability, reliability, and component durability. Improper use of a work tool resulting in sweeping, prying, twisting and/or catching of heavy loads will reduce the life of the boom and stick.



## Bucket Specifications and Compatibility

With Center Lock Coupler									320E L**	320E L
	Linkage	Width		Capacity		Weight		Fill	Boom (HD)	SLR
		mm	in	m <sup>3</sup>	yd <sup>3</sup>	kg	lb	%	2.9 ES (9'6")	6.28 m (20'6")
General Duty (GDC)	B	600	24	0.55	0.72	618	1,363	100%	●	
	B	750	30	0.75	0.98	710	1,566	100%	●	
	B	900	36	0.95	1.24	786	1,733	100%	●	
	B	1050	42	1.16	1.52	847	1,867	100%	●	
	B	1200	48	1.38	1.80	925	2,038	100%	⊙	
	B	1350	54	1.59	2.08	1002	2,209	100%	⊖	
Heavy Duty (HD)	B	600	24	0.46	0.61	649	1,430	100%	●	
	B	750	30	0.64	0.84	747	1,647	100%	●	
	B	900	36	0.81	1.06	825	1,818	100%	●	
	B	1050	42	1.00	1.31	879	1,937	100%	●	
	B	1200	48	1.19	1.56	970	2,138	100%	●	
	B	1350	54*	1.38	1.81	1051	2,316	100%	⊖	
Severe Duty (SD)	B	600	24	0.46	0.61	693	1,527	90%	●	
	B	750	30	0.64	0.84	801	1,765	90%	●	
	B	900	36	0.81	1.06	887	1,955	90%	●	
	B	1050	42	1.00	1.31	962	2,121	90%	●	
	B	1200	48	1.19	1.56	1051	2,316	90%	●	
	B	1200	48	1.19	1.56	1000	2,204	90%	●	
Maximum load with coupler (payload + bucket)								kg	3410	
								lb	7,516	

The above loads are in compliance with hydraulic excavator standard EN474, they do not exceed 87% of hydraulic lifting capacity or 75% of tipping capacity with front linkage fully extended at ground line with bucket curled.

Capacity based on ISO 7451.

Bucket weight with General Duty tips.

\*This bucket might reduce boom structure life.

\*\*Heavy counterweight configuration with 5.4 mt (5.9 ton) counterweight.

### Maximum Material Density:

- 2100 kg/m<sup>3</sup> (3,500 lb/yd<sup>3</sup>)
- ⊙ 1800 kg/m<sup>3</sup> (3,000 lb/yd<sup>3</sup>)
- ⊖ 1500 kg/m<sup>3</sup> (2,500 lb/yd<sup>3</sup>)
- 1200 kg/m<sup>3</sup> (2,000 lb/yd<sup>3</sup>)

Caterpillar recommends using appropriate work tools to maximize the value customers receive from our products. Use of work tools, including buckets, which are outside of Caterpillar's recommendations or specifications for weight, dimensions, flows, pressures, etc. may result in less-than-optimal performance, including but not limited to reductions in production, stability, reliability, and component durability. Improper use of a work tool resulting in sweeping, prying, twisting and/or catching of heavy loads will reduce the life of the boom and stick.