



MC305-2

MINI CRAWLER CRANE

6,560 lb. maximum capacity

- 5 SECTION BOOM - 41'0"
- BOOM TIP SEARCH HOOK (optional)
46'10" MAXIMUM LIFTING HEIGHT
- CONFINED AREA 3 POSITION
OUTRIGGER SYSTEM
- RUBBER TRACKS
- 2 SPEED TRAVEL &
ALL CRANE FUNCTIONS
- MOMENT LIMITER DIGITAL
LOAD SYSTEM
- ANTI TWO BLOCK,
TILT SENSOR ALARM
- 360° SWING
- AUTOMATIC HOOK
STOWAGE
- OPERATOR'S SEAT WITH
CENTRALIZED CONTROLS
- REMOTE CONTROL WITH
LOAD CAPACITY DISPLAY
- EPA COMPLIANT DIESEL
ENGINE, DUAL POWER
ELECTRIC MOTOR (optional)

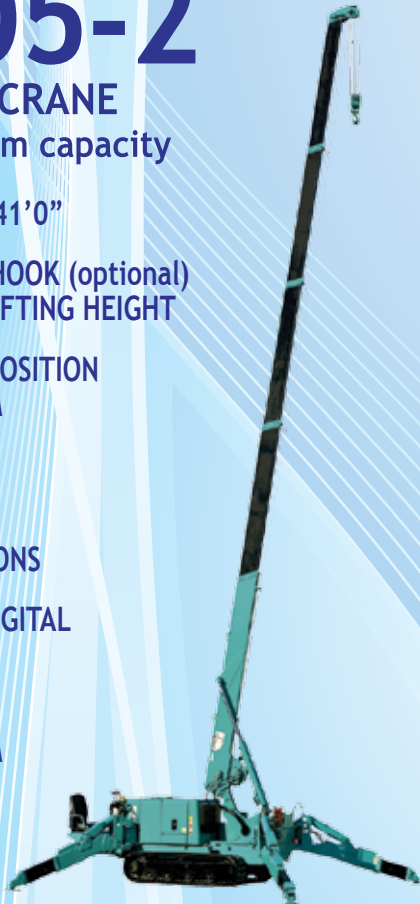

Searcher Hook (Optional)

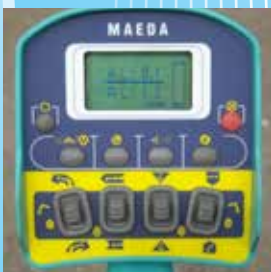

Remote Control



Moment Limiter Digital Load System

Maximum Capacity		4 Part Line: 6,560lb. 2 Part Line: 3,260lb. / 1 Part Line: 1,650lb. Boom Tip Searcher Hook: 1,870lb.
Maximum Working Radius		Main Boom: 39.8' Boom Tip Searcher Hook: 43.0'
Maximum Lifting Height		Hook Block, Ball: 41.0' Boom tip Searcher Hook: 46.8'
Hook Speed		44' / min 4 Part / 4th Layer
Single Line Speed		177' / min 4th Layer
Hoist Rope		IWRC 6 x WS(26) 8mm x 240'
Boom System	Type Length Telescopic Stroke / Speed	Automatic 5 Section, Pentagonal Telescopic 12'1" - 41'0" 29' / 38 sec. [26 sec.]
Outriggers		3 Position, Lower and Extend by Direct Acting Hydraulic Cylinders, Manual Swing-out and Pin.
Boom Hoist	Angle / Speed	0° - 80° / 21 secs [14.5 sec.]
Swing	Radius / Speed	360° / 1.7 RPM [2.4 RPM]
Travel Crawler System	Drive Travel Speed Gradability	Hydraulic Motor, Stepless Speed Changer 0 - 1.7 mph 23° Design Limit 15° Set Limit
	Ground Contact Track Ground Pressure	5'9" Length, 12" Wide 5.30 PSI Diesel Model 5.48 PSI Electric Dual Power Model
Engine	Type Rated Output Fuel Tank	Yanmar 3TNV80F-SNMB, EPA Tier 4 Final 4 Cycle, 3 Cylinder, Diesel, Water Cooled 20.38 hp, 15.3kw, 20.7 ps / 2500 RPM 10.5 Gallon
Electric Motor (Dual Power)	Type Size	Totally Enclosed Fan Cooled Motor 5.5 kw, 4P, 230V, 3 phase, Inverter 30 hz - 60 hz
Remote Control	Standard	Cable Remote Control, Crane & Outrigger Operation, Graduated Micro Speed, Load & Rated Load LCD Display
Dimensions	Stowed LxWxH	L 14'1" x W 4'3" x H 5'7"
Net Weight		Diesel Model 8,550 lb. Electric Dual Power +400 lb.
Optional Equipment		Boom Tip Searcher Hook, Wireless Remote, White Rubber Tracks, Single Part Ball/Hook, Man Basket, Rotation Resistant Wire Rope, Oktopus Glass Lifter Manipulator, Custom Paint Color, Exhaust Scrubber, Transport Trailer, Outrigger Pads

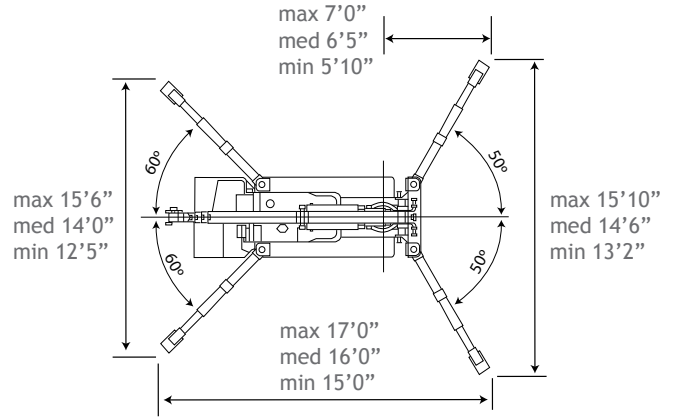
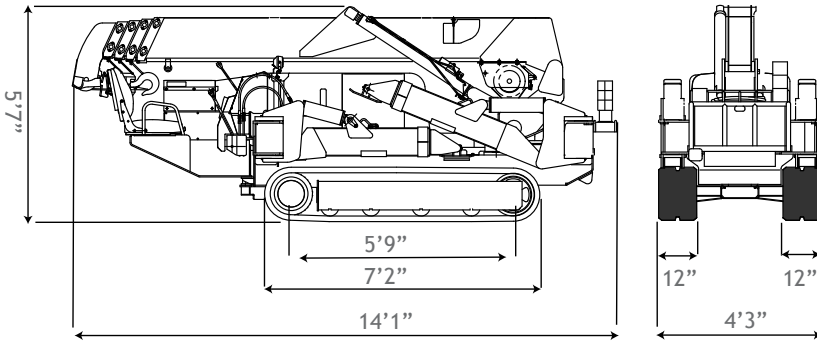

RATED TOTAL LOAD - MAXIMUM Outriggers, 4 Part Line

Boom Length	12.1 Ft.	12.2 - 19.5 Ft.	19.6 - 26.7 Ft.	26.8 - 33.8 Ft.	33.9 - 41.0 Ft.
Radius (Ft.)	Load (Lbs.)	Load (Lbs.)	Load (Lbs.)	Load (Lbs.)	Load (Lbs.)
≤ 8.0	6,560	6,560			
8.5	6,280	6,280	5,000		
10.0	5,160	5,160	4,590		
11.5		4,370	3,690		
13.0		3,810	3,200	2,380	
14.5		3,350	2,830	2,200	1,740
17.0		2,830	2,340	1,890	1,370
18.0		2,640	2,180	1,790	1,270
20.0			1,890	1,670	1,120
23.0			1,600	1,470	940
25.5			1,390	1,300	850
29.0				1,120	760
32.5				970	680
36.0					610
39.5					570

WORKING RANGE

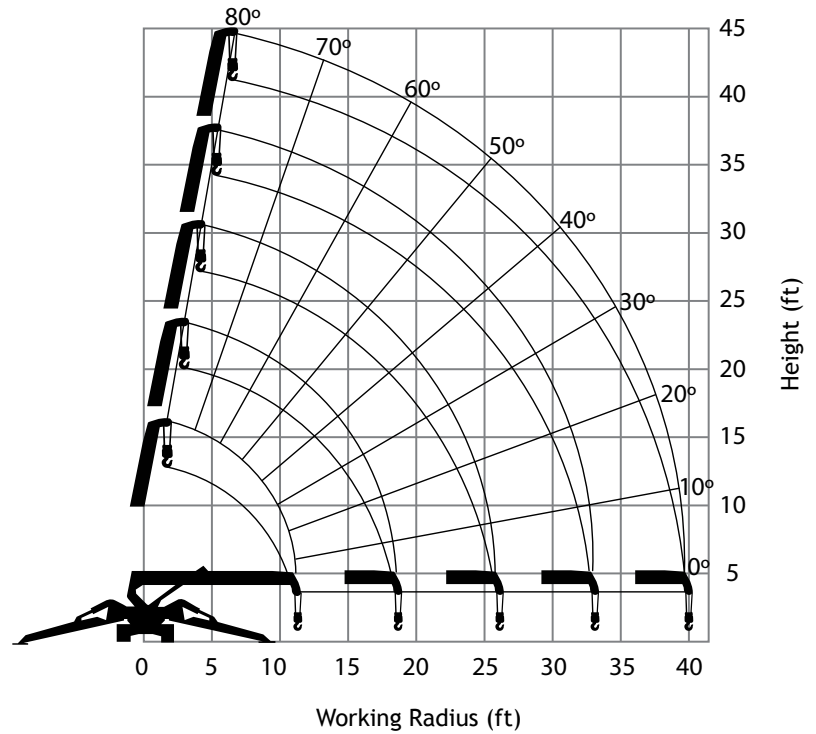

RATED TOTAL LOAD - MEDIUM Outriggers, 4 Part Line

Boom Length	12.1 Ft.	12.2 - 19.5 Ft.	19.6 - 26.7 Ft.	26.8 - 33.8 Ft.	33.9 - 41.0 Ft.
Radius (Ft.)	Load (Lbs.)	Load (Lbs.)	Load (Lbs.)	Load (Lbs.)	Load (Lbs.)
≤ 8.0	6,560	6,560			
8.5	6,260	6,260	5,000		
10.0	5,100	5,100	4,530		
11.5		4,310	3,690		
13.0		3,750	3,160	2,330	
14.5		3,140	2,790	2,120	1,710
17.0		2,360	2,250	1,840	1,350
18.0		2,160	2,100	1,760	1,240
20.0			1,700	1,630	1,070
23.0			1,340	1,380	900
25.5			1,150	1,140	810
29.0				920	710
32.5				780	640
36.0					570
39.5					550

Reach Below Grade

Four Part	53' max.
Two Part	105' max.
One Part	211' max.

RATED TOTAL LOAD - MINIMUM Outriggers, 4 Part Line

Boom Length	12.1 Ft.	12.2 - 19.5 Ft.	19.6 - 26.7 Ft.	26.8 - 33.8 Ft.	33.9 - 41.0 Ft.
Radius (Ft.)	Load (Lbs.)	Load (Lbs.)	Load (Lbs.)	Load (Lbs.)	Load (Lbs.)
≤ 8.0	6,560	6,560			
8.5	6,260	6,260	5,000		
10.0	5,050	5,050	4,530		
11.5		3,950	3,690		
13.0		3,200	3,060	2,330	
14.5		2,600	2,550	2,120	1,710
17.0		1,970	1,890	1,820	1,350
18.0		1,800	1,740	1,700	1,240
20.0			1,430	1,460	1,070
23.0			1,120	1,160	890
25.5			950	970	810
29.0				770	710
32.5				660	640
36.0					530
39.5					460

The Rated Total Load is based on the actual working radius including boom deflection. Due to wire rope strength and other limitations, when using two part or single part hooks use the appropriate four part Rated Total Load Chart but with maximum load of:

Two Part - 3,260 lb Single Part - 1,650 lb.

The Rated Total Load Chart is supplied for reference only. Operator and all personnel must refer to the actual crane Rated Total Load Chart to determine allowable machine lifting and operating procedures. We are constantly improving our products and reserve the right to change design and specifications at any time.

ASME B 30.5 2014. ISO 9001 compliant