

Shuttlelift CD7725

Product Guide

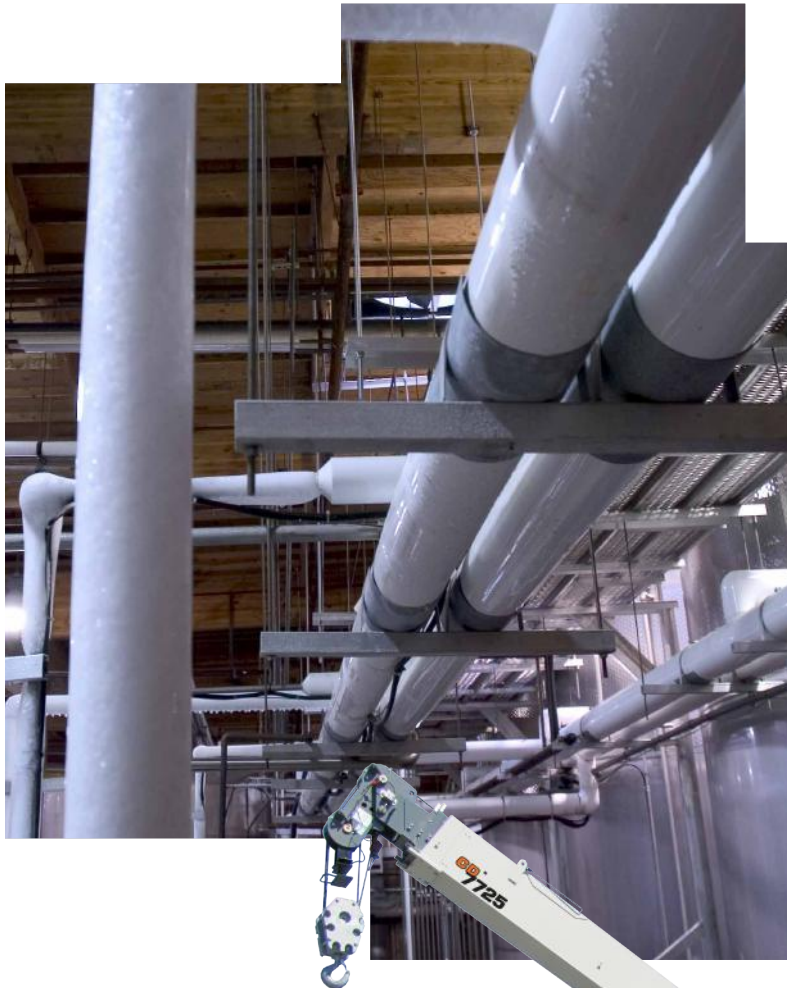

Features

- 22 t (25 USt) capacity
- 21,6 m (71 ft) four-section full power boom
- 13,6 t (15 USt) deck carrying capacity
- Tilt steering wheel
- Load sensing piston hydraulic pump
- Proportional hydraulic controls





The reach and capacity to get the job done

A 5,1 m (17 ft) swingaway extension added to the 21,6 m (71 ft) main boom provides an impressive 28,9 m (95 ft) tip height with a capacity of 2268 kg (5000 lb). A galvanized down-haul ball is included with the extension.

Split door design

The “new” split door design, offered with the optional enclosed cab, allows for the top half to be left open while keeping the bottom half closed for safety.



Specifications

4

Dimensions

7

Range diagram

9

Load chart

10

Symbols glossary

12



Hook block

A galvanized coated hook block is provided as standard to help eliminate rusting of this important crane component.

Operator cab

Hydraulic proportional joystick controls, automotive dash layout, tilt steering wheel, and suspension seat enhances operator comfort and ease of use.

Specifications

Superstructure

Boom

7,21 m – 21,6 m (23 ft 8 in - 71 ft) full power main boom. Four-section boom with three (3) powered sections.

Maximum tip height: 24,0 m (79 ft).

*Offsettable swingaway extension

5,1 m (17 ft) offsettable swingaway extension. Offsets 0°, 15°, and 30° via pivoting boom nose. Stows alongside base boom section.

Maximum tip height: 28,9 m (95 ft).

Boom nose

Two nickel plated steel sheaves mounted on heavy duty tapered roller bearings with removable pin-type rope guards. Quick reeve type boom nose with four-position (0°, +30°, +60°, and +80°) pivoting to minimize head height requirements. Lowers head height by 0,6 m (2 ft).

Boom elevation

Two double acting hydraulic cylinders with integral holding valves provides elevation from -0° to +80°.

Anti-two block device

Standard anti-two block device, which, when activated, provides an audible warning to the operator and “locks-out” all functions whose movement can cause two-blocking.

Load indicator (LSI)

A simple effective and easy to use load indicating system used in conjunction with the anti-two block system to assist the operator in efficient operation of the unit within the limits of the load chart. The display panel displays the hook load and cuts-out the telescope and boom lift down function when a load limit is exceeded. The warning is by a flashing light on the display panel. In conjunction with the load display panel (receiver) there is a wireless transmitter and load sensing pin attached to the boom head that transmits the hook load to the display panel.

(**wireless system**)

*Load Moment Indicator (LMI)

“Graphics Display” of boom angle, boom length, boom radius, capacity, and allows for operator input to set the limit parameters based on the load chart. Displays color coded light bar and audible alarm with function cut-out if load exceeds the load chart parameters.

(**hardwired system**)

Swing

Ball bearing swing circle with 360° continuous rotation. Hydraulic motor driven pinion with brake. Maximum speed: 2.5 rpm

Hydraulic system

One pressure compensated variable displacement axial piston pump with load sensing combined with two (2) gear pumps.

Maximum output of: 238 LPM (79 GPM).

Maximum operating pressure: 248 bars (3600 psi).

Six section valve bank, chassis mounted, operated via dash mounted, pilot pressure hydraulic joysticks. 227 L (60 gal) hydraulic reservoir with sight level gauge and steel side plating to guard against side impacts.

10 micron return line filter with full flow by-pass protection and service indicator.

Hoist specifications

Piston motor driven with automatic spring applied / hydraulically released wet brake.

Maximum hoist pull (first layer): 6804 kg (15,000 lb)

Maximum permissible single line pull:
5670 kg (12,500 lb) (3.5:1 design factor)

Maximum single line speed: 61 m/min (200 fpm)

Rope construction: 6X19 XIPS/IWRC

Rope diameter: 16 mm (5/8 in)

Rope length:
Main hoist: 119 m (390 ft)

Maximum rope stowage:
Main hoist: 151 m (495 ft)

Carrier

Chassis

High strength alloy frame constructed with integral outrigger housings; front and rear lifting, tie-down, and towing lugs. 60 ft² carrydeck size with 13 608 kg (30,000 lb) deck only carrying capacity. Deck coated with anti-skid treatment.

Outriggers

Two-stage hydraulic telescoping beam with vertical jack at the four corners provides extended and down and retracted and down lifting capacities. Integral holding valves on both beam and jack cylinders.

Outrigger pad size:

29,2 cm x 29,2 cm (11.5 in x 11.5 in)

Maximum outrigger pad load:

20 321 kg (44,800 lb) / 339 p.s.i.

Outrigger controls

Independent outrigger control rocker switches for beam or jack selection with separate extend/retract rocker switch. 360° bubble level located inside cab.

Engine (Tier IV)

Cummins QSB 4.5 L, four cylinders, turbo-charged diesel rated at 97 kW (130 hp) at 2500 rpm. Standard 110V engine block heater and cold weather intake grid heater.

Diesel Oxidation/Catalyst, stainless steel, muffler to meet 2012 EPA emissions, combined with a Cummins direct air flow, 2 stage cyclonic air filter system.

Maximum torque: 620 N-m (457 ft lb) at 1500 rpm.

Note: Tier IV engine Required in North American and European Union countries.

Engine (Tier III)

Cummins QSB 4.5L, four cylinders / turbo-charged diesel rated at 97 kW (130 bhp) (Gross) at 2500 rpm. Standard 110V engine block heater and cold weather “ether” assist system. Engine hour meter located inside operators compartment.

Maximum torque: 370 N-m (273 ft lb) at 2500 rpm.

Note: Required for sale outside of North American and European Union countries

Fuel tank capacity

189 L (50 gal)

Shuttlelift CD7725

Specifications

Transmission

Powershift with four speeds forward and reverse. Stalk mounted direction shifter with rotary gear selection.

Operators control station

Frame mounted, open air style control station with cab shell includes all crane functions, driving controls, and overhead safety glass. Other standard equipment includes a suspension seat with seat belt, hourmeter, sight level bubble, and 2.5 lb (1.1 kg) fire extinguisher. The dash panel includes a multi-cluster gauge showing fuel, water temperature, oil pressure, and battery voltage. An engine monitoring indicator strip shows engine warning, stop engine, transmission low pressure, transmission high temperature, and low brake system pressure. The load indicator receiver is mounted to the top of the dash panel.

*Operators control station enclosed

Includes the standard cab shell with the addition of front, rear, and right side glass, a split (2 piece) hinged door with sliding glass, front windshield wiper and washer, hot water heater and defroster with fan and cab dome light are included.

Electrical system

Two 12V maintenance-free batteries, 820CCA at 0°. 63 amp alternator.

Drive

2 wheel (rear drive) or 4 wheel selection, front and rear axle drive with planetary hubs and limited slip differential.

Steer

Standard three steering modes. Front two wheel, four-wheel coordinated, and four-wheel crab steer with electronic self alignment, three-position rocker selector on dash panel.

Outside turning radius:

Two-wheel steer: 7,32 m (24 ft)

Four-wheel steer: 4,04 m (13 ft 3 in)

Specifications

Carrier continued

Suspension/axles

Front: Drive/steer with differential and planetary reduction hubs, axle is rigid mounted to frame.

Rear: Drive/steer with differential and planetary reduction hubs, axle is pivot mounted to frame allows up to 3.5° of oscillation.

Oscillation lockouts

Manual switch to engage and disengage the rear axle lockouts. Engage when lifting on rubber and in crab steer mode, Disengage to allow oscillation when traveling over rough terrain.

Brakes

Hydraulic actuated internal wet-disc service brake acting on all four wheels. Dash mounted toggle switch with light for activating or release of the dry disc parking brake mounted on the transmission output yoke.

Tires

Standard: 17.5 x 25 Bias

Optional: 17.5R25 radials

Lights

Full lighting including turn indicators, head, tail, brake and hazard warning lights recessed mounted.

Maximum speed

31,3 km/h (19.5 mph)

Gradeability (theoretical)

63%..... (at engine stall) NO LOAD

38%.....(at engine stall) with 13 608 kg (30,000 lb) DECK LOAD

Gross vehicle weight (G.V.W.)

Open cab: 20 249 kg (44,640 lb)

Enclosed cab: 20 354 kg (44,873 lb)

Miscellaneous standard equipment

22 t (25 USt) Two sheave “galvanize coated” hook block, with “Quick Reeve”.

Back-up motion alarm

Outrigger motion alarm

Dual rear-view mirrors

*Optional equipment

- ▶ **AUXILIARY LIGHTING:** includes cab mounted amber flashing light, dual base boom mounted floodlights
- ▶ **CONVENIENCE PACKAGE:** includes front and rear pintle hitch and headlight/taillight grille covers
- ▶ **ENCLOSED CAB PACKAGE:** includes heater and defroster, cab dome light, all window glass, and two piece split door
- ▶ 5,2 m (17 ft) fixed extension
- ▶ Air conditioner
- ▶ Catalytic convertor
- ▶ Hoist drum rotation indicator
- ▶ Wire rope 3rd wrap indicator with hoist function cut-out
- ▶ 3629 kg (8000 lb) below deck mounted tow winch
- ▶ Foam – filled tires

Dimensions

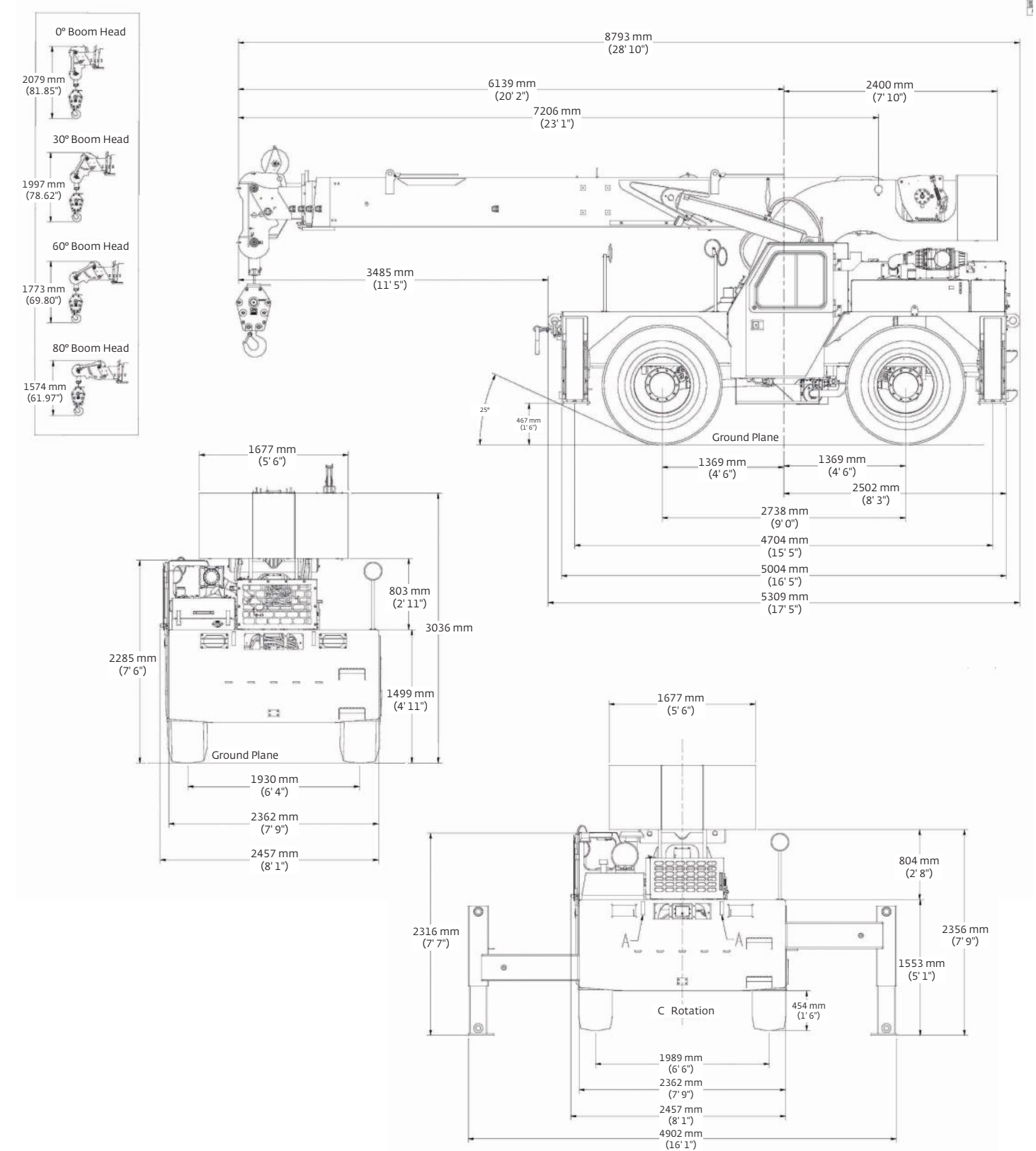

Dimensions

Range diagram

Dimensions										
Tire size	A	B	C	D	E	A	B	C	D	E
17.5 x 25	9784 mm (385.2 in)	8047 mm (316.8 in)	7620 mm (300 in)	7300 mm (287.4 in)	4664 mm (183.6 in)	7102 mm (279.6 in)	4968 mm (195.6 in)	4542 mm (178.8 in)	4084 mm (160.8 in)	1890 mm (74.4 in)
	Two-wheel steer					Four-wheel steer				

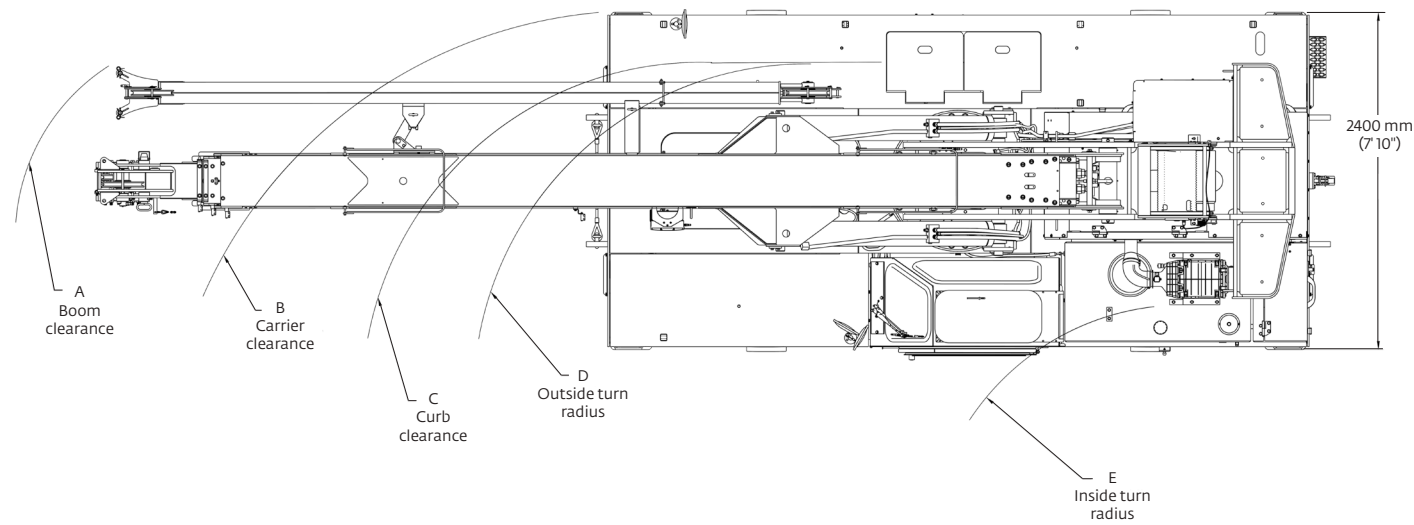

Weights						
	GVW		Front		Rear	
	kg	(lb)	kg	(lb)	kg	(lb)
Basic machine: Including 21,6 m (71 ft) main boom, main hoist with 119 m (390 ft) of wire rope, 22,6 t (25 USt) hookblock, full counterweight, Tier IV engine	20 249	(44,640)	9 904	(21,834)	10 345	(22,806)
Add: 5,1 m (17 ft) fixed swingaway extension and extension carrier brackets and downhaul weight	208	(458)	406	(896)	-199	(-438)
Crane weight	20 456	(45,098)	10 310	(22,730)	10 146	(22,368)
Basic machine: Including 21,6 m (71 ft) main boom, main hoist with 119 m (390 ft) of wire rope, 22,6 t (25 USt) hookblock, full counterweight, Tier IV engine	20 249	(44,640)	9 904	(21,834)	10 345	(22,806)
Add: Enclosed cab with heater and defroster	106	(233)	104	(104)	129	(129)
Crane weight	20 354	(44,873)	9 951	(21,938)	10 403	(22,935)

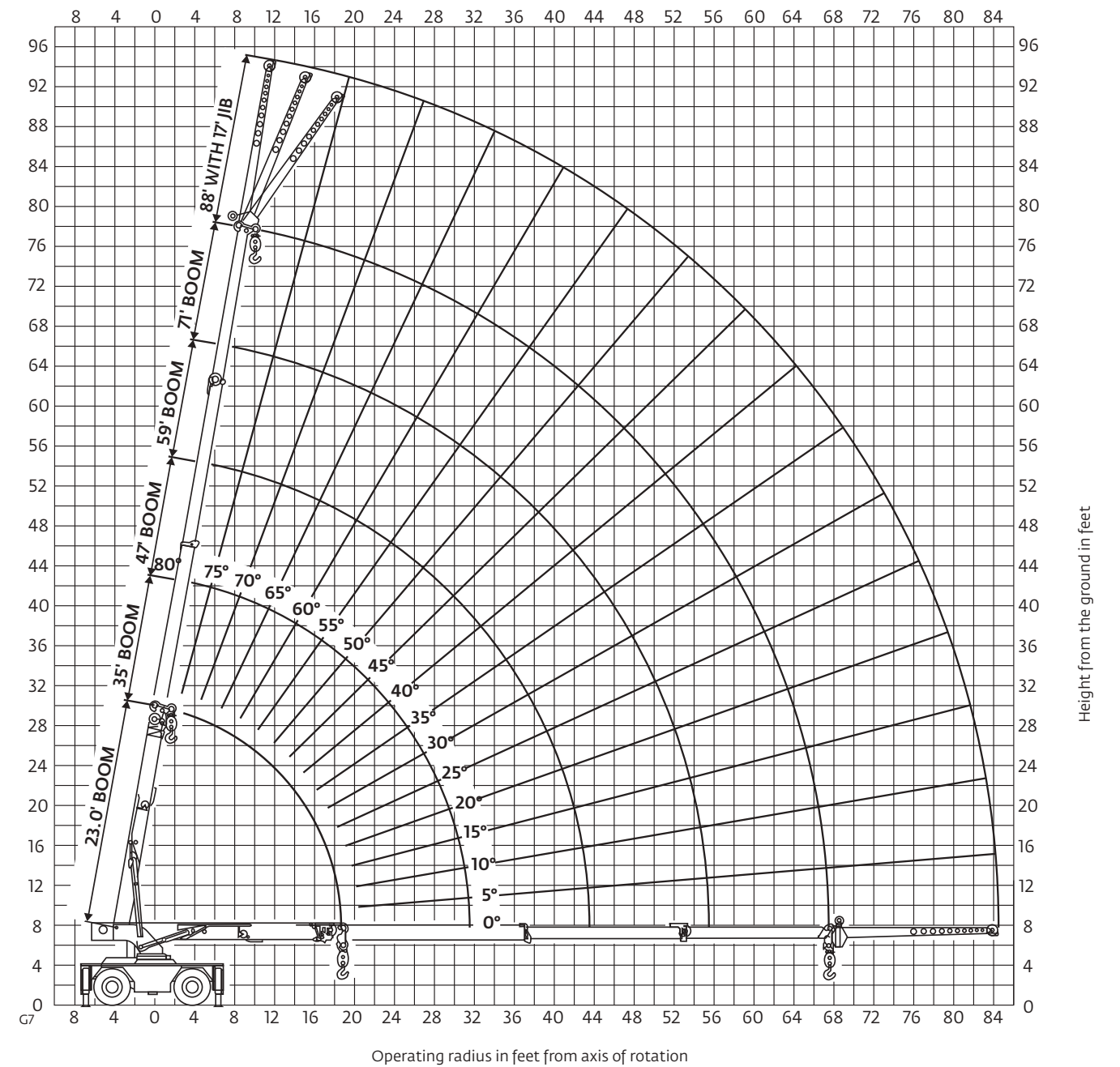

Load chart

Load chart

MAIN BOOM LOAD RATINGS ON OUTRIGGERS Extended and Down 360° or Retracted and Down Front/Rear										MAIN BOOM LOAD RATINGS ON OUTRIGGERS Retracted and Down 360°											
23.0 ft Boom		35.0 ft Boom		47.0 ft Boom		59.0 ft Boom		71.0 ft Boom		23.0 ft Boom		35.0 ft Boom		47.0 ft Boom		59.0 ft Boom		71.0 ft Boom			
Radius (ft)	Rated Load (lb)	Rated Angle (deg)	Rated Load (lb)	Rated Angle (deg)	Rated Load (lb)	Rated Angle (deg)	Rated Load (lb)	Rated Angle (deg)	Rated Load (lb)	Radius (ft)	Rated Load (lb)	Rated Angle (deg)	Rated Load (lb)	Rated Angle (deg)	Rated Load (lb)	Rated Angle (deg)	Rated Load (lb)	Rated Angle (deg)	Rated Load (lb)		
8.5	50,000	73.2	34,300	78.1	33,600	79.7	27,800			8.5	63.5	26,350	73	24,000	78	21,900					
10	38,793	70.6	34,500	76.2	33,017	77.8	25,900			10	59	20,800	70.5	19,300	76	17,900	79.5	16,650			
12	34,893	66.9	31,426	73.6	29,285	77.8	25,900			12	52.5	16,000	67	15,100	73.5	14,200	77.5	13,350			
14	46.8	63.2	28,464	71	26,357	75.8	24,100	78.7	18,200	14	45.5	12,300	63	12,250	71	11,600	75.5	11,000			
16	38.8	59.2	26,076	68.3	24,016	73.7	22,400	77.1	16,750	16	37	9,850	55.5	10,150	68.5	9,700	73.5	9,280	79	10,500	
18	38.8	55.1	23,496	65.6	22,096	71.7	20,792	75.4	15,500	18	26	8,070	55.5	8,370	65.5	8,230	71.5	7,910	75.5	7,590	
19.5	0	21,044	51.9	21,379	63.5	20,902	70.1	19,582	74.2	14,650	19.5	0	7,090	52	7,300	63.5	7,330	70	7,060	74	6,810
22			46	18,471	59.9	18,629	67.4	17,872	72	13,400	22			46.5	5,900	60	6,050	67.5	5,900	72	5,720
24			40.8	16,592	56.9	16,747	65	16,300	70.3	12,500	24			41.5	5,040	57	5,170	65	5,150	70	5,000
26			36	14,600	54	14,850	63	14,200	68.5	11,750	26			36	4,330	54	4,450	63	4,520	68.5	4,400
28			29	12,750	51	13,050	60.5	13,150	66.7	11,050	28			29	3,740	51	3,850	60.5	3,930	66.5	3,850
30			20	11,250	47.5	11,600	58.5	11,700	65.2	9,800	30			20	3,250	47.5	3,340	58.5	3,410	65	3,420
31.5			0	10,300	45	10,650	56.5	10,750	63.9	9,400	31.5			0	2,910	45	3,010	56.5	3,080	63.5	3,120
34					40	9,350	53.5	9,480	61.5	8,850	34					40	2,530	53.5	2,590	61	2,640
36					36	8,460	51	8,590	59.6	8,400	36					36	2,200	51	2,260	59	2,310
38					31	7,680	48.5	7,830	57	7,940	38					31	1,910	48.5	1,960	57	2,010
40					25	7,000	45.5	7,150	55	7,270	40					25	1,660	45.5	1,700	55	1,750
42					17.5	6,400	42.5	6,550	53	6,680	42					17.5	1,410	42.5	1,470	53	1,510
43.5					0	6,000	40.5	6,000	51.5	6,270	43.5					0	1,230	40.5	1,310	51.5	1,350
46							36	5,440	48.5	5,680	46							36	1,070	48.5	1,110
48							32.5	5,040	46.5	5,250	48							32.5	890	46.5	930
50							28	4,680	44	4,860	50							28	720	44	780
52							23	4,350	41.5	4,510	52							23	570	41.5	630
54							16	4,040	38.5	4,190	54							16	430	38.5	500
55.5							0	3,820	36.5	3,960	55.5							0	330	36.5	410
58									32.5	3,620	58									32.5	270
60										29	3,370	60									
62										25	3,130	62									
64										20	2,920	64									
66										13	2,720	66									
67										0	2,620	67									

Main Boom Angle (deg)	17 ft JIB CAPACITY ON EXTENDED OUTRIGGERS (lb)				
	Jib Offset Angle				30° Any Boom Length
	0°		15°		
To 55 ft Main Boom	To 71 ft Main Boom	To 55 ft Main Boom	To 71 ft Main Boom		
80	—	—	5000	5000	3500
75	7500	—	4400	4400	3100
70	6100	—	3900	3900	2800
65	5000	4600	3500	3500	2550
60	4300	3800	3150	3150	2350
55	3800	3300	2850	2850	2200
50	3400	2900	2600	2600	2100
45	3050	2600	2400	2400	2000
40	2800	2400	2250	2250	1950
35	2600	2150	2150	2050	1900
30	2400	1930	2080	1850	1830
25	2300	1750	2050	1720	—
20	2200	1600	2000	1590	—
15	2100	1500	1950	1520	—
10	2050	1460	—	—	—
5	2020	1450	—	—	—
0	2000	1440	—	—	—

MAIN BOOM ON RUBBER Any Boom Length		
Radius (ft)	Front Rating (lb)	360° Rating (lb)
6	30,000	21,000
8	24,950	17,900
10	21,000	15,000
12	18,000	13,000
14	15,650	10,000
16	13,300	7920
18	10,900	6410
20	9460	5780
22	8060	4880
24	6960	4140
26	6050	3520
28	5300	2990
30	4670	2540
32	4130	2160
34	3670	1820
36	3260	1530
38	2900	1270
40	2590	1040
42	2300	830
44	2280	720
46	2050	610
48	1840	500
50	1650	390
52	1480	280
54	1320	—
56	1220	—
58	1080	—
60	950	—
62	840	—
64	730	—
66	620	—
67	570	—

NOTES:
JIB CAPACITY IS LIMITED BY BOTH STRUCTURAL CAPACITY CHART AND MAIN CAPACITY CHART.

SHADED AREAS ARE GOVERNED BY STRUCTURAL STRENGTH, DO NOT RELY ON TIPPING.

OPERATION OF THIS EQUIPMENT IN EXCESS OF RATING CHARTS AND DISREGARD OF INSTRUCTIONS IS DANGEROUS AND VOIDS WARRANTY.

1) The rated loads are the maximum lift capacities as determined by operating radius, boom length and boom angle. The operating radius is the horizontal distance from a projection of the axis of rotation to the supporting surface, before loading, to the center of vertical hoist line or tackle with load applied.

2) Rated load columns for discrete boom lengths apply when actual boom length is within +/- 1.0 ft of discrete length. When boom length or radius or both are between points listed on capacity chart, the smallest load shown at either the next larger radius or boom length shall be used.

3) For operating radius not shown, use load rating of next larger radius.

4) The rated loads shown on outriggers do not exceed 85% of actual tipping. The rated loads shown on rubber do not exceed 75% of actual tipping. These ratings are based on freely suspended loads with the crane leveled, standing on a firm, uniform supporting surface. Practical working loads depend on supporting surface, operating radius and other factors affecting stability. Hazardous surroundings, climatic conditions, experience of personnel and proper training must all be taken into account by the operator.

RATING REDUCTIONS FOR LOAD HANDLING DEVICES INSTALLED (lb)		
	FROM MAIN BOOM	FROM JIB
MAIN BLOCK	475	N/A
HOOK & BALL	100	100
JIB STOWED	0	N/A
JIB DEPLOYED	500	0

MAXIMUM PERMISSIBLE SINGLE LINE PULL = 12,500 lb
HOIST ROPE: 5/8 in diameter
6 x 19 XIPS IWRC BRIGHT
Min. req'd breaking strength = 45,400 lb

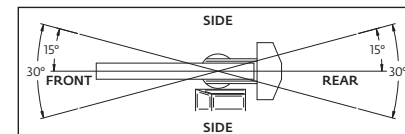

5) The weights of all load handling devices such as hooks, hook blocks, slings, etc., except the hoist rope, shall be considered part of the load. See reduction chart.

6) Ratings on outriggers are for either outriggers fully extended and down or fully retracted and down. Ratings for outriggers fully retracted and down will apply for any intermediate outrigger setting.

7) Ratings on rubber depend on tire capacity, condition of tires and proper inflation pressure (110 psi). When replacing tires, contact Manitowoc for proper specifications. Loads on rubber may be transported at a maximum speed of 2.5 mph on a smooth, hard, level surface with boom retracted to the shortest length possible and centered over front. For 360° ratings on rubber, rear axle oscillation locks must be in place. Do not use jib with crane on rubber.

8) The maximum combined total boom and deck load is 20,000 lb. The maximum deck load only is 30,000 lb.

9) Do not induce any external side loads to boom or jib.

80024664CD

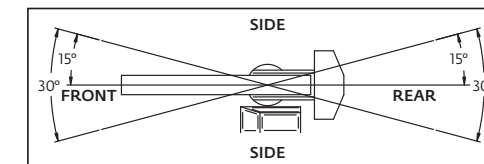

1) The rated loads are the maximum lift capacities as determined by operating radius, boom length and boom angle. The operating radius is the horizontal distance from a projection of the axis of rotation to the supporting surface, before loading, to the center of vertical hoist line or tackle with load applied.

2) Rated load columns for discrete boom lengths apply when actual boom length is within +/- 1.0 ft of discrete length. When boom length or radius or both are between points listed on capacity chart, the smallest load shown at either the next larger radius or boom length shall be used.

3) For operating radius not shown, use load rating of next larger radius.

4) The rated loads shown on outriggers do not exceed 85% of actual tipping. The rated loads shown on rubber do not exceed 75% of actual tipping. These ratings are based on freely suspended loads with the crane leveled, standing on a firm, uniform supporting surface. Practical working loads depend on supporting surface, operating radius and other factors affecting stability. Hazardous surroundings, climatic conditions, experience of personnel and proper training must all be taken into account by the operator.

5) The weights of all load handling devices such as hooks, hook blocks, slings, etc., except the hoist rope, shall be considered part of the load. See reduction chart.

6) Ratings on outriggers are for either outriggers fully extended and down or fully retracted and down. Ratings for outriggers fully retracted and down will apply for any intermediate outrigger setting.

7) Ratings on rubber depend on tire capacity, condition of tires and proper inflation pressure (110 psi). When replacing tires, contact Manitowoc for proper specifications. Loads on rubber may be transported at a maximum speed of 2.5 mph on a smooth, hard, level surface with boom retracted to the shortest length possible and centered over front. For 360° ratings on rubber, rear axle oscillation locks must be in place. Do not use jib with crane on rubber.

8) The maximum combined total boom and deck load is 20,000 lb. The maximum deck load only is 30,000 lb.

9) Do not induce any external side loads to boom or jib.

80024664CD

Transportation and lifting data

TRANSPORTATION AND LIFTING DATA - CD7725

- LIFTING OF ENTIRE CRANE OR MAJOR CRANE ASSEMBLIES MUST BE ACCOMPLISHED BY UTILIZING SPECIFIC FITTINGS INDICATED ON ADJACENT CHART. USE OF FITTINGS FOR PURPOSES OTHER THAN THOSE DESIGNATED ON CHART IS PROHIBITED. FITTING CAPACITIES ARE MAXIMUM ALLOWABLE LOADS PER INDIVIDUAL FITTING.
- RIGGING PERSONNEL SHALL BE RESPONSIBLE FOR PROPER SELECTION AND PLACEMENT OF ALL SLINGS AND LOAD HANDLING DEVICES.
- DIMENSIONS AND WEIGHTS SHOWN ARE ESTIMATED FOR LARGEST CONFIGURATION AVAILABLE. WEIGHTS DO NOT INCLUDE BOOM EXTENSION AND OR JIB, UNLESS OTHERWISE INDICATED.
- RIGGING PERSONNEL SHALL VERIFY DIMENSIONS AS REQUIRED FOR CLEARANCE.
- DO NOT USE COUNTERWEIGHT LIFT LOCATIONS OR BOOM SLING POINT FOR LIFTING OR TIE DOWN OF ENTIRE CRANE.
- LIFTING OF THE COUNTERWEIGHT TO BE ACCOMPLISHED WITH A PROPERLY RATED 1/2 INCH EYEBOLT.

FITTING	NO. / UNIT				BOOM	CWT	CAPACITY-TONNES [TONS]				
		LIFT	TOW	TIE DOWN			LIFT	LIFT	TIE DOWN		
									FORE & AFT	SIDE	DOWN
A	4	X	X	X			9.1 [10]	27.2 [30]	27.2 [30]	0.9 [1]	27.2 [30]
B	4				X		1.8 [2]				
C	1					X	0.9 [1]				
D	1					X	0.9 [1]				

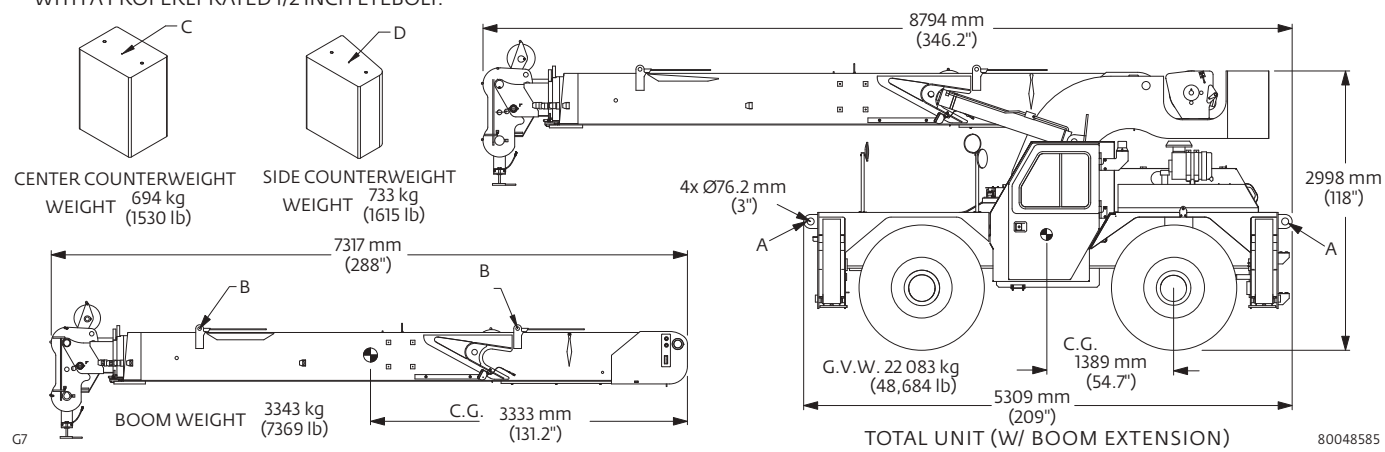

LOAD DISTRIBUTION CHART

AREA 1	
5,21 m sq (56.1 sq ft)	8981 kg (19,800 lb)
AREA 2	
2,41 m sq (25.9 sq ft)	4627 kg (10,200 lb)

- Maximum travel speed with any or all loads - 4,0 km/h (2.5 mph)
- Loads to be transported on smooth level surfaces only.
- Boom must be retracted and in center forward position.
- Any combination or total of areas 1 and 2 may be used.
- Lifting is not permitted when carry deck is loaded except for loading and unloading carry deck.
- Rated pick and carry loads may be transported on deck area 1 provided the load is cribbed directly on the frame rails.

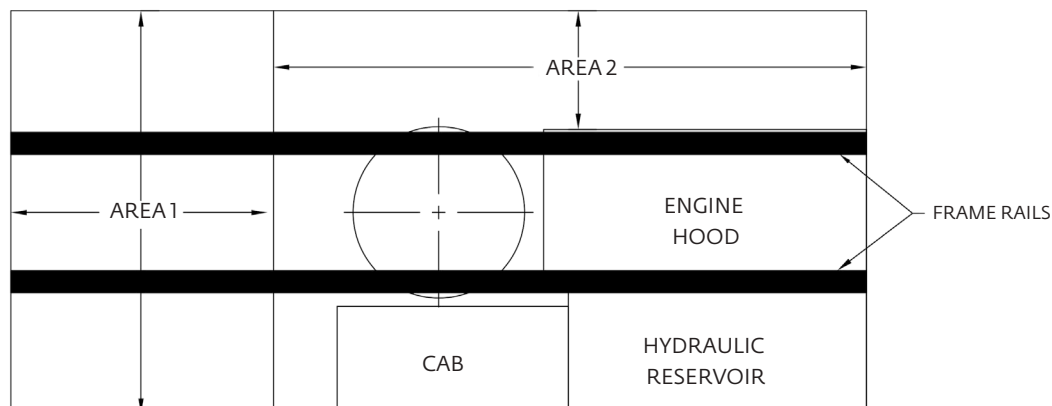

Symbols glossary

Axles	Counterweight	Grade	Outriggers
Boom	Drive	Heavy duty jib	Radius
Boom elevation	Electrical system	Hoist	Rotation
Boom extension	Engine	Hookblock	Speed
Boom length	Extension	Hydraulic system	Steering
Boom nose	Frame	Lights	Suspension
Brakes	Fuel tank capacity	Oil	Swing
Cab	Gear	Outrigger controls	Tires
			Transmission

Manitowoc Cranes

Regional headquarters

Americas

Manitowoc, Wisconsin, USA

Tel: +1 920 684 6621

Fax: +1 920 683 6277

Shady Grove, Pennsylvania, USA

Tel: +1 717 597 8121

Fax: +1 717 597 4062

Europe, Middle East, Africa

Ecully, France

Tel: +33 (0)4 72 18 20 20

Fax: +33 (0)4 72 18 20 00

China

Shanghai, China

Tel: +86 21 6457 0066

Fax: +86 21 6457 4955

Greater Asia-Pacific

Singapore

Tel: +65 6264 1188

Fax: +65 6862 4040

Regional offices

Americas

Brazil

Alphaville

Mexico

Monterrey

Chile

Santiago

Europe, Middle East, Africa

Czech Republic

Netvorice

France

Baudemont

Cergy

Decines

Germany

Langenfeld

Hungary

Budapest

Italy

Lainate

Netherlands

Breda

Poland

Warsaw

Portugal

Baltar

Russia

Moscow

South Africa

Johannesburg

U.A.E.

Dubai

U.K.

Buckingham

China

Beijing

Chengdu

Guangzhou

Xian

Greater Asia-Pacific

Australia

Brisbane

Melbourne

Sydney

India

Chennai

Delhi

Hyderabad

Pune

Korea

Seoul

Philippines

Makati City

Singapore

Factories

Brazil

Passo Fundo

China

TaiAn

Zhangjiagang

France

Charlieu

Moulins

Germany

Wilhelmshaven

India

Pune

Italy

Niella Tanaro

Portugal

Baltar

Fânzeres

Slovakia

Saris

USA

Manitowoc

Port Washington

Shady Grove

This document is non-contractual. Constant improvement and engineering progress make it necessary that we reserve the right to make specification, equipment, and price changes without notice. Illustrations shown may include optional equipment and accessories and may not include all standard equipment.