

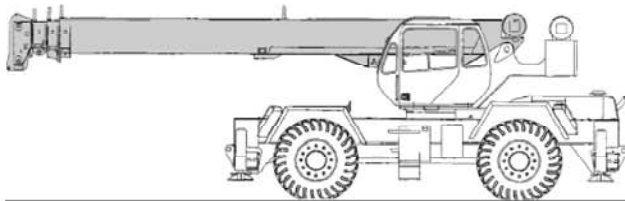

RT300 SERIES

rough terrain cranes
specifications



STANDARD BOOM EQUIPMENT

BOOM

30-94 ft. (9.23-28.78 m), four section full power, mechanically synchronized boom. High-strength four plate construction with side plate holes. Anti-friction slide pads. Single boom hoist cylinder. Maximum tip height is 100 ft. (30.48 m).

BOOM HEAD

Welded to fourth section of boom. Four or five load sheaves and two idler sheaves mounted on heavy duty, anti-friction bearings. Quick reeving boom head. Provisions made for side-stow jib mounting.

OPTIONAL BOOM EQUIPMENT

JIBS

32 ft. (9.68 m) side stow swing-on one-piece lattice type jib. Single sheave mounted on anti-friction bearing. Jib is offsettable at 0°, 15°, or 30°. Maximum tip height is 129 ft. (39.32 m) with 94 ft. (28.49 m) boom.

32-49 ft. (9.68 -14.86 m) side-stow swing-on lattice type jib. Single sheave mounted on anti-friction bearing. Jib is extendible to 49 ft. (14.86 m) by means of a 17 ft. (5.18m) manual pull-out tip section, roller supported for ease of extension. Jib is offsettable at 0°, 15°, or 30°. Maximum tip height is 147 ft. (44.81 m) with 94 ft. (28.49 m) boom.

AUXILIARY BOOM HEAD

Removable auxiliary boom head has single sheave mounted on anti-friction bearing. Removable pin-type rope guard for quick reeving. Installs on main boom peak only. Removal is not required for jib use.

HOOK BLOCK

Three or four metallic sheaves on anti-friction bearings with hook and heavy duty hook latch.

HOOK & BALL

7.0 ton (6.3 mt) top swivel ball with hook and hook latch.

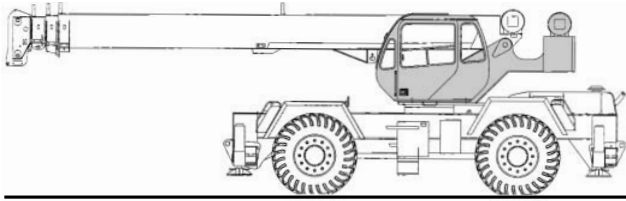

STANDARD UPPERSTRUCTURE EQUIPMENT

UPPERSTRUCTURE FRAME

All welded one-piece structure fabricated with high tensile strength alloy steel. Counterweight is removable.

TURNTABLE CONNECTION

Swing bearing is a single row, ball type, with external teeth. The swing bearing is bolted to both the revolving upperstructure and the carrier.

SWING

A hydraulic motor drives a double planetary reduction gear for precise and smooth swing function. Swing speed (no load) is 2.8 rpm.

SWING BRAKE

Heavy duty multiple disc swing brake is mechanically actuated from operator's cab by foot pedal. Brake may be locked on or used as a momentary brake.

RATED CAPACITY INDICATOR

Rated Capacity Indicator with visual and audible warning system and automatic function disconnects. Second generation pictographic display includes: boom radius, boom angle, boom length, allowable load, actual load, and percentage of allowable load registered by bar graph. Operator settable alarms provided for swing angle, boom length, boom angle, tip height, and work area exclusion zone. Anti-two block system includes audio/visual warning and automatic function disconnects.

OPERATOR'S CAB

Environmental cab with all steel construction, optimized visibility, tinted safety glass throughout, and rubber floor matting is mounted on vibration absorbing pads. The cab has a sliding door on the left side, framed sliding window on the right side, hinged tinted all glass skylight and removable front

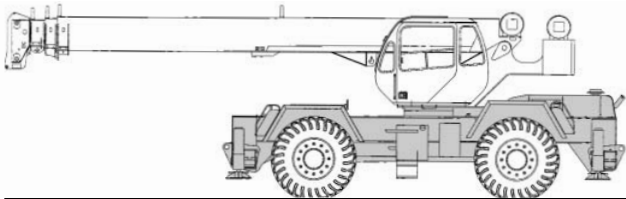

STANDARD CARRIER EQUIPMENT

CARRIER CHASSIS

High strength chassis with four-wheel drive and four-wheel steer (4x4x4). Has box beam type construction with reinforcing cross members, a precision machined turn table mounting plate and integrally welded outrigger boxes. Decking has anti-skid surfaces, including tool storage compartment, and access steps and handles left and right side and front and rear corners.

AXLES AND SUSPENSION

Rear axle is a planetary drive/steer type with automatic oscillation lockouts that engage when the superstructure is swung 10° in either direction. Front axle is a planetary drive/steer type, rigid mounted to the frame for increased stability.

windshield to provide optimized visibility of the load open or closed. Acoustical foam padding insulates against sound and weather. The deluxe six-way adjustable operator's seat is equipped with a torsion bar suspension and includes head and arm rests.

CONTROLS

All control levers and pedals are positioned for efficient operation. Hand operated control levers include swing, boom telescope, boom hoist, winch(s), shift, vernier adjustable hand throttle, and 360° house lock. Switches include ignition, engine stop, steering mode, parking brake, two speed winch, and outrigger controls. Foot control pedals include swing brake, boom raise, boom lower, service brakes and accelerator.

INSTRUMENTATION AND ACCESSORIES

In-cab gauges include air pressure, bubble level, engine oil pressure, fuel, engine coolant temperature, voltmeter, transmission temperature, transmission charge pump pressure. Indicators include low air, high coolant temperature/low engine oil pressure/high transmission temperature audio/visual warning, low coolant audio/visual warning, hoist drum rotation indicator, Rated Capacity Indicator and rear axle centered. Accessories include fire extinguisher; light package including headlights, tail light, brake lights, directional signals, four-way hazard flashers, dome & dash lights, and back-up lights with audible back-up alarm; windshield washer/wiper; skylight wiper; R.H. and L.H. rear view mirrors; and seat belt.

HYDRAULIC CONTROL VALVES

Valves are mounted in the rear of the upperstructure and are easily accessible. Valves are mechanically operated and include one three spool valve for boom elevation, telescope, and main winch; and one single spool valve for swing. High pressure regeneration feature provides 2-speed boom extension. Quick disconnects are provided for quick connection of pressure check gauges.

OPTIONAL EQUIPMENT

Auxiliary Winch • Heater/Defroster • Air Conditioner • Work Lights • Revolving Amber Light • Independent Rear Wheel Steering • Roof Mounted Spotlight

STEERING

Hydraulic four-wheel power steering for two-wheel, four-wheel, or crab steer is easily controlled by steering wheel.

Turning radius to center of outside tire.

	23.5R25 tires	21.00x25 tires
Two-wheel:	36' 10.75" (11.25 m)	36' 8.7" (11.19 m)
Four-wheel:	20' 4.7" (6.22 m)	20' 2.6" (6.16 m)

TRANSMISSION

Full power-shift transmission with integral torque converter has neutral safety start, 6 speeds forward, and 3 speeds reverse. Automatic pulsating back-up alarm.

STANDARD CARRIER EQUIPMENT (continued)

MULTI-POSITION OUT & DOWN OUTRIGGERS

Fully independent hydraulic outriggers may be utilized fully extended to 22 ft. (6.71 m), in their 1/2 extended position, or fully retracted. Easily removable floats, each with an area of 254 in² (1639 cm²), stow on the carrier frame. Complete controls and sight leveling bubble are located in the operator's cab.

WHEELS & TIRES

Disc type wheels with full tapered bead seat rim. 150.50 in (3.82 m) wheelbase.

TIRES

23.5R25** std.
21.00x25 28 PR opt.

SERVICE BRAKES

Cam operated air brakes on all four wheels; 20¹/₄" x 4" (51.43x10.2 cm) drum brakes.

PARKING BRAKE

Front and rear axles equipped with spring-set, air released emergency/parking chambers.

OPTIONAL EQUIPMENT

Cold Weather Starting Aid • Immersion Heater • 24" (0.61m) Aluminum Outrigger Floats • Pintle Hook • Clearance Lights • Front Mounted Winch – 20,000 lbs (9072 kg)

HYDRAULIC SYSTEM

HYDRAULIC PUMPS

Three gear type pumps, one single and two in tandem, driven off the transmission. Combined system capability is 119 gpm (450 lpm). Includes pump disconnect.

Main and Auxiliary Winch Pump

59.5 gpm (225.2 lpm) @ 3,500 psi (246.1 kg/cm²)

Boom Hoist, Telescope Pump

38.5 gpm (145.7 lpm) @ 3,500 psi (246.1 kg/cm²)

Power Steering, Outrigger and Swing Pump

21 gpm (79.5 lpm) @ 2,500 psi (175 kg/cm²)

FILTRATION

Full flow oil filtration system with bypass protection includes a removable 60 mesh (250 micron) suction screen-type filter and 5 micron replaceable return line filter.

HYDRAULIC RESERVOIR

All steel, welded construction with internal baffles and diffuser. Provides easy access to filters and is equipped with an external sight level gauge. The hydraulic tank is pressurized to aid in keeping out contaminants and in reducing potential pump cavitation. Capacity is 114 gal (432 liters). Hydraulic oil cooler is standard.

MAIN WINCH SPECIFICATION

Hydraulic winch with bent axis piston motor and planetary reduction gearing provides 2-speed operation with equal speeds for power up and down. Winch is equipped with an integral automatic brake, grooved drum, tapered flanges, standard cable roller on drum, and electronic rotation indicator.

PERFORMANCE	LO-RANGE	HI-RANGE
Max. line speed (no load)		
First layer	184 fpm (56.1 m/min)	369 fpm (112.5 m/min)
Fifth layer	266 fpm (81.1 m/min)	533 fpm (162.5 m/min)
Max. line pull-first layer	15,639 lbs (7094 kg)	7,298 lbs (3310 kg)
Max. line pull-fifth layer	10,827 lbs (4911 kg)	5,052 lbs (2292 kg)
Permissible line pull	9,000 lbs (4082 kg)	

DRUM DIMENSIONS	DRUM CAPACITY
10.62 in (270 mm) drum diameter	Max. Storage: 570 ft (173.7 m)
17.55 in (446 mm) length	6th layer not a working layer
18.0 in (457 mm) flange dia.	Max. Useable: 455 ft (138.7 m)*
Cable: 5/8 in. x 450 ft (16 mm x 137.2 m)	
Cable type: 5/8 in. (16mm) 6x19 IWRC	* Based on min. flange height above
XIPS right regular lay, preformed	top layer to comply with ANSI B30.5

OPTIONAL AUX. WINCH

Hydraulic 2-speed winch with bent axis piston motor, power up and down, equal speed, planetary reduction with integral automatic brake, grooved drum with tapered flanges, drum roller, and rotation indicator.

PERFORMANCE

(Same as main winch)

DRUM DIMENSIONS AND CAPACITY

(Same as main winch)

OPTIONAL HOIST LINE – MAIN WINCH AND OPTIONAL AUXILIARY WINCH –

5/8 in. (16mm) rotation resistant compacted strand 18 x 19 or 19 x 19.

Min. breaking strength 22.6 tons (20.6 mt).

ENGINE SPECIFICATIONS

Make and Model	Cummins 6BT5.9 (Std.)	Caterpillar 3116 DITA (Opt.)
Type	6 cylinder	6 cylinder
Bore and Stroke	4.02 x 4.72 in (102x120 mm)	4.12 x 5.0 in (105x127mm)
Displacement	359 cu in (5.9 l)	402 cu in (6.6 l)
Gross Horsepower	152 @ 2,500 rpm	175 @ 2,400 rpm
Gross Torque	414 lb•ft(561 N•m) @ 1600 rpm	490 lb•ft(664 N•m) @ 1450 rpm
Aspiration	turbocharged	turbocharged & aftercooled
Air Filter	dry type	dry type
Electrical System	12 volt	12 volt
Alternator	102 amp	115 amp
Battery	(2) 12V-1600 CCA	(2) 12V-1600 CCA
Fuel Capacity	50 gal (189 l)	50 gal (189 l)

PERFORMANCE (Standard Engine)

Transmission Gear	Forward Drive	Maximum Speed	Maximum Tractive Effort	Gradeability @ Stall*
1	4-wheel	2.3 mph 3.7 km/h	56,357 lbs 25 564 kg	273.7%
2	4-wheel	4.1 mph 6.6 km/h	31,890 lbs 14 465 kg	59.5%
3	4-wheel	5.4 mph 8.7 km/h	24,261 lbs 11 005 kg	41.6%
4	2-wheel	9.6 mph 15.4 km/h	13,746 lbs 6235 kg	21.4%
5	2-wheel	13.6 mph 21.9 km/h	9,691 lbs 4396 kg	14.3%
6	2-wheel	24.0 mph 38.6 km/h	5,498 lbs 2494 kg	7.2%

*Based on a gross vehicle weight of 60,000 lbs. (27 216 kg).

GENERAL DIMENSIONS

NOTES:

- Dimensions given assume the boom is fully retracted in travel position and 23.5R25 tires. Add 3.0" (76 mm) for 21.00x25 tires.
- Minimum ground clearance under:
 - transmission - 21.62" (549 mm)
 - axle bowls - 18.65" (474 mm)

3. Approach and departure angles:
- | | | |
|---------------------|---------|----------|
| | 23.5R25 | 21.00x25 |
| Approach angle (A) | - 22° | 26° |
| Departure angle (B) | - 18° | 21° |

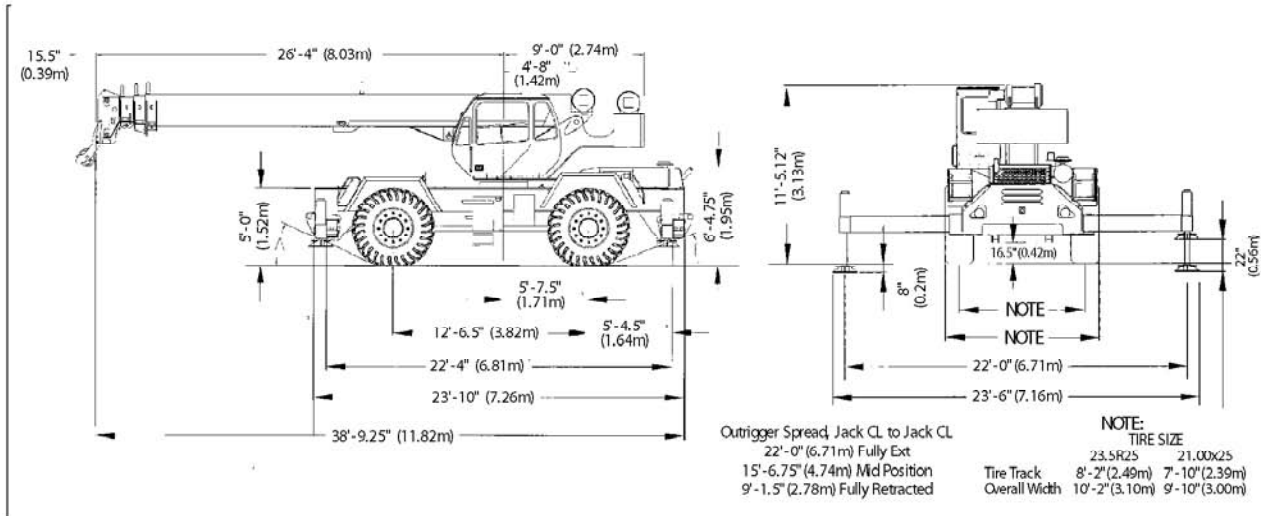

WEIGHTS & AXLE LOADS	GROSS WEIGHT LBS.	UPPER FACING FRONT		GROSS WEIGHT KG.	UPPER FACING FRONT	
		FRONT	REAR		FRONT	REAR
Basic Crane with 10,000 lb. (4536 kg) Counterweight	63,260	30,388	32,872	28 694	13 784	14 910
Add Options:						
32' (9.68 m) Swing-on jib (Stowed)	+ 1,368	+ 1,814	- 446	+ 621	+ 823	- 202
32'-49' (9.68 - 14.86 m) Swing-on Jib (Stowed)	+ 1,789	+ 2,147	- 358	+ 811	+ 974	- 163
Auxiliary Boom Head	+ 100	+ 260	- 160	+ 45	+ 118	- 73
Auxiliary Winch Controls and Plumbing Only	+ 75	+ 0	+ 75	+ 34	+ 0	+ 34
Auxiliary Winch with Wire Rope, Controls, Etc.	+ 264	- 56	+ 320	+ 120	- 25	+ 145
40T (36.3 mt) 4-Sheave Hook Block	+ 690	+ 1,017	- 327	+ 313	+ 461	- 148
30T (27.2 mt) 3-Sheave Hook Block	+ 670	+ 987	- 317	+ 304	+ 448	- 144
25T (22.7 mt) 2-Sheave Hook Block	+ 682	+ 1,005	- 323	+ 309	+ 456	- 147
6.25T Hook and Ball (In tool box)	+ 240	+ 261	- 21	+ 109	+ 118	- 9
Pintle Hook: Front	+ 45	+ 64	- 19	+ 20	+ 29	- 9
Rear	+ 45	- 22	+ 67	+ 20	- 10	+ 30
Substitute:						
450' (137.2 m) of 18x19 class spin resistant wire rope	+ 60	- 39	+ 99	+ 27	+ 18	+ 45

NOTE: Weights are for factory supplied equipment and are subject to 2% variation due to manufacturing tolerances. WE RESERVE THE RIGHT TO AMEND THESE SPECIFICATIONS AT ANY TIME WITHOUT NOTICE. THE ONLY WARRANTY APPLICABLE IS OUR STANDARD WRITTEN WARRANTY APPLICABLE TO THE PARTICULAR PRODUCT AND SALE. WE MAKE NO OTHER WARRANTY, EXPRESSED OR IMPLIED.



TEREX Cranes
 106 12th Street S.E.
 Waverly, IA 50677-9466 USA
 TEL: +1 (319) 352-3920
 FAX: +1 (319) 352-5727
 EMAIL: inquire@terexwaverly.com
 WEB: terex.com